



www.lighting.philips.co.in

PHILIPS

Signature
Lighting Collection

Your **vision,** our solutions

Light up and bring life to spaces with our
Signature Lighting Collection



Light is
possibility

A possibility to make an impact on people. A possibility to make each day better.

A possibility to

explore
and create
the **future**
with light

Light has the ability to alter spaces in exciting and inspiring ways. Whether you want to improve people's health, make cities safer or make businesses prosperous, light makes it possible.



“Light is joy. People respond to light. It makes places lively and engaging.”

Barry Richards
Principal and Studio Leader, Rockwell Group

Explore the **possibilities of light**

08

Lighting themes

40

Choose the right LED

44

Lighting collection

232

Learn about lighting

234

Customer testimonials

Light up

your vision of the future

Today, creative visionairs are creating immersive experiences and exploring new ways of using light to alter the way people feel about their surroundings.

These lighting solutions are at intersection of technology, community and sustainability and have been grouped into six themes.

Six lighting themes

01 **Unite**
Page 10 - 13



Highlighting city landmarks to create a sense of security, pride and belonging among city communities.

02 **Express**
Page 14 - 17



Pairing light with different media and movement to build new stories and dynamic experiences for viewers.

03 **Guide**
Page 18 - 21



Light appearing as an additional layer to give directional cues and information when needed, and fade away when not required.

04 **Heal**
Page 22 - 25



Leveraging lighting innovations to embed the healing qualities of light into everyday experiences.

05 **Communicate**
Page 26 - 29

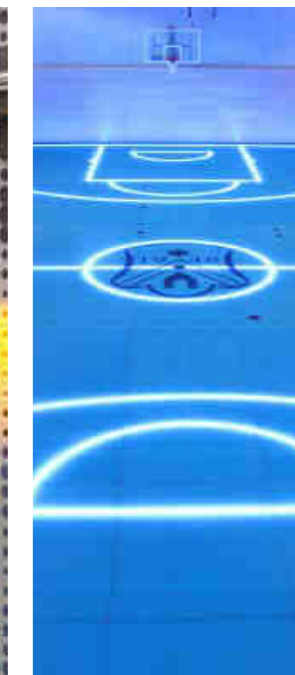

Lighting used creatively to share experiences, whether close or near, to create meaningful conversations.

06 **Empower**
Page 30 - 33

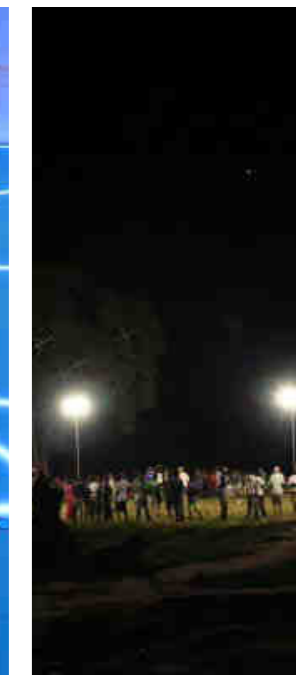

Using alternative energy to power low-cost lighting solution; creating new opportunities for the under-served.

01 Unite

Discover urban spaces re-imagined by designers and enhanced by the use of light. These visual displays are redefining the urban landscape and creating new experience points in cities. Increasingly, initiatives such as these are becoming indicative of a vibrant and engaging city life.

A gas station transforms into a communal art installation ▶

Two derelict gas stations from the 1980s have been transformed by the use of LED panels and spotlights, creating an artificial sky. The installation also features concrete furniture that encourages people to stop and interact. The project has become a great example of a shared, dynamic space within the humdrum of the city.

Installation: Sophie Valla, LED cloud project



Marking the **2022 FIFA world cup** in Qatar

To celebrate the upcoming FIFA World Cup in 2022, architects are creating an enormous lit crystal ball in Qatar. The crystal ball building will host a sports museum and a shopping centre, and will transform into a glowing orb as soon as the sun goes down. During the day, its crystallized exterior will reflect the rays of the sun, filtering ample daylight into the interior space. The orb body also rests on the vertical axis, and spins gradually in a spiral path.

Installation: Vedran Pedišić, Erick Velasco Farerra



Iconic **San Francisco Bridge** pulses with light

25,000 LEDs blink and shimmer to create morphing patterns and shapes on San Francisco's most well-known landmark, the Bay Bridge. This large scale installation spans along the bridge and along the bridge supports. This largely donation driven project is one of the world's largest LED sculptures; 1.8 miles wide and 55 feet high.

Installation: Leo Villareal using Philips Color Kinetics technology

02 Express

Designers are leveraging advanced sensor technology to develop environments that respond to proximity, touch and sound, creating vibrant lighting displays and graphic images.

Installation captures and replicates movement

Future Self is a performance, light and sound installation that maps and replicates movement. As two dancers move around the installation, 3D cameras record the shapes made by their bodies and replay them on a grid of over 10,000 LED lights. The image created by the lights resembles a single figure, no matter how many people approach it at once.

*Installation: Random International, MADE exhibition, Berlin
Choreographer: Wayne McGregor
Composer: Max Richter*



Interactive sculpture **responds to sound and movement**

Fiet is an interactive sculpture that visualizes the emotional impact of movement. The installation is made of hundreds of cones which move based on the sounds in the environment. For instance, if there is a sudden noise the sculpture tenses up, but when it's quiet and peaceful it has a fluid motion. The result is an installation that resembles a living organism, responding to its surroundings.

Installation: Studio Toer

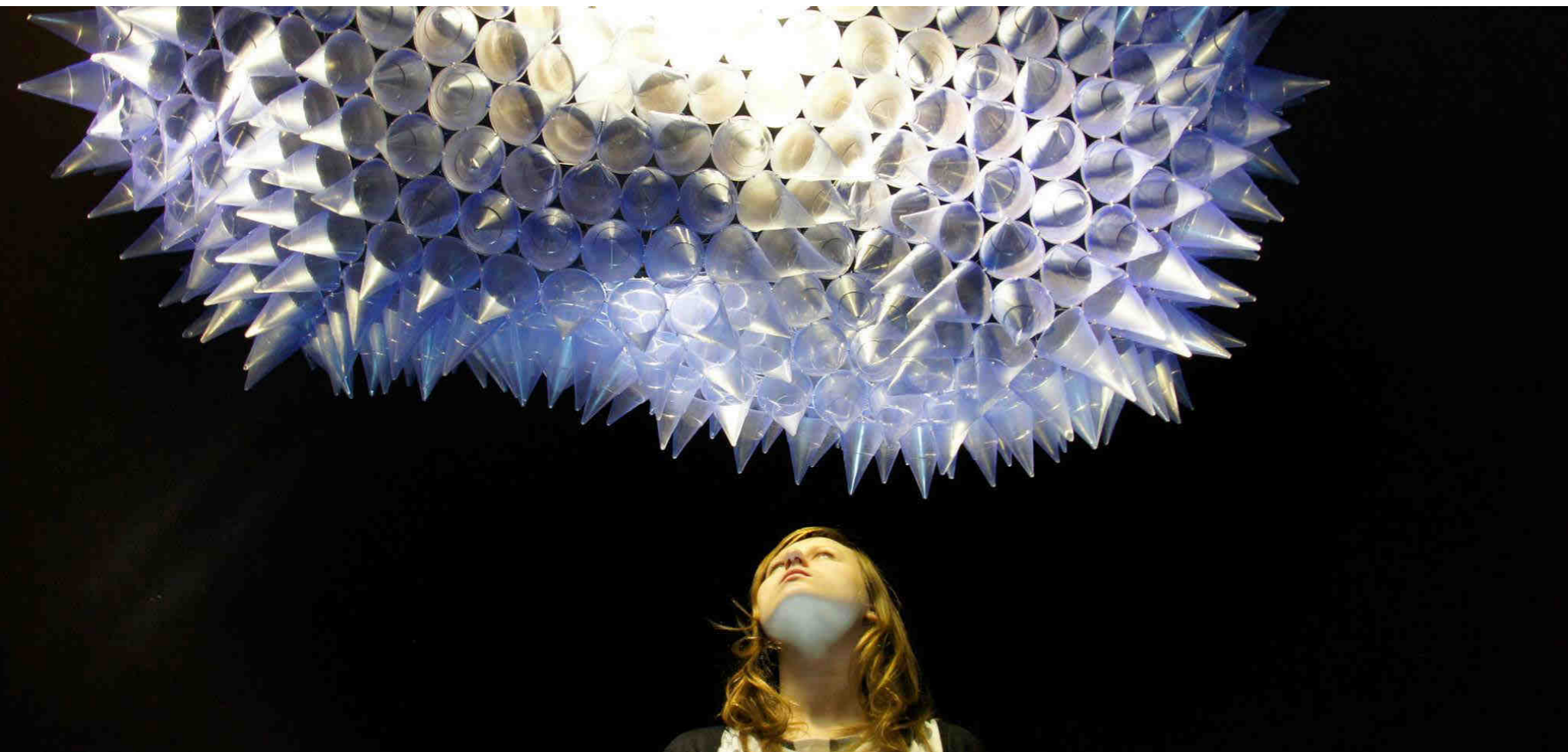

Installation trees **lean and sway towards visitors** as they approach

Inaho, ear of corn in Japanese, is an array of freestanding LED bulbs shaped like golden ears of rice. These stalks low and gently lean towards an approaching visitor. Tiny perforations along the golden carbon fiber rice stems distribute the light, making the installation look like a paddy field gently rippling in the wind.

Installation: Yoshimoto and Yoshinaka Ono, Tangent Studio

03 Guide

Advances in projection technology, mapping of directional cues and heads up displays are enhancing way finding and safety. Personal displays with context relevant information can help a shopper looking for a special gift or making their way home in a new city faster and stress-free. Collected and artistically visualized data is increasingly becoming a part of urban landscape displays.

An impossible to miss, **stop sign projected in mid air** ▶

The Sydney Harbour Tunnel in Australia uses light and water to project stop signs that appear to float in midair. The Softstop barrier system produces a pseudo-holographic 'Stop' message that is impossible for drivers to miss. The concept solves the persistent problem of drivers ignoring signals that are in the peripheral vision, by bringing warning messages right in the direct field of vision.

Installation: Laservision





◀ Supermarket **LEDs send discounts** to shopper phones

Korean supermarket chain Emart uses smartphones and LED lights to guide shoppers to discounts. 'Emart Sale Navigation' uses special LED ceiling lights to send information to smartphones. Once shoppers install the Emart app they are guided by dedicated indoor maps, and when they pass an area with a discount coupon available, a notification pops up on their screen.

Installation: Emart

Safety flood lights are triggered when streets fill with water

Safety Light is a road lighting concept that is activated when streets are underwater after a severe storms hit. The rainwater triggers a water activated battery, which in turn powers embedded LEDs, sending up beams of light. The lights help define lane markings clearly for drivers to find their way safely through flooded areas.

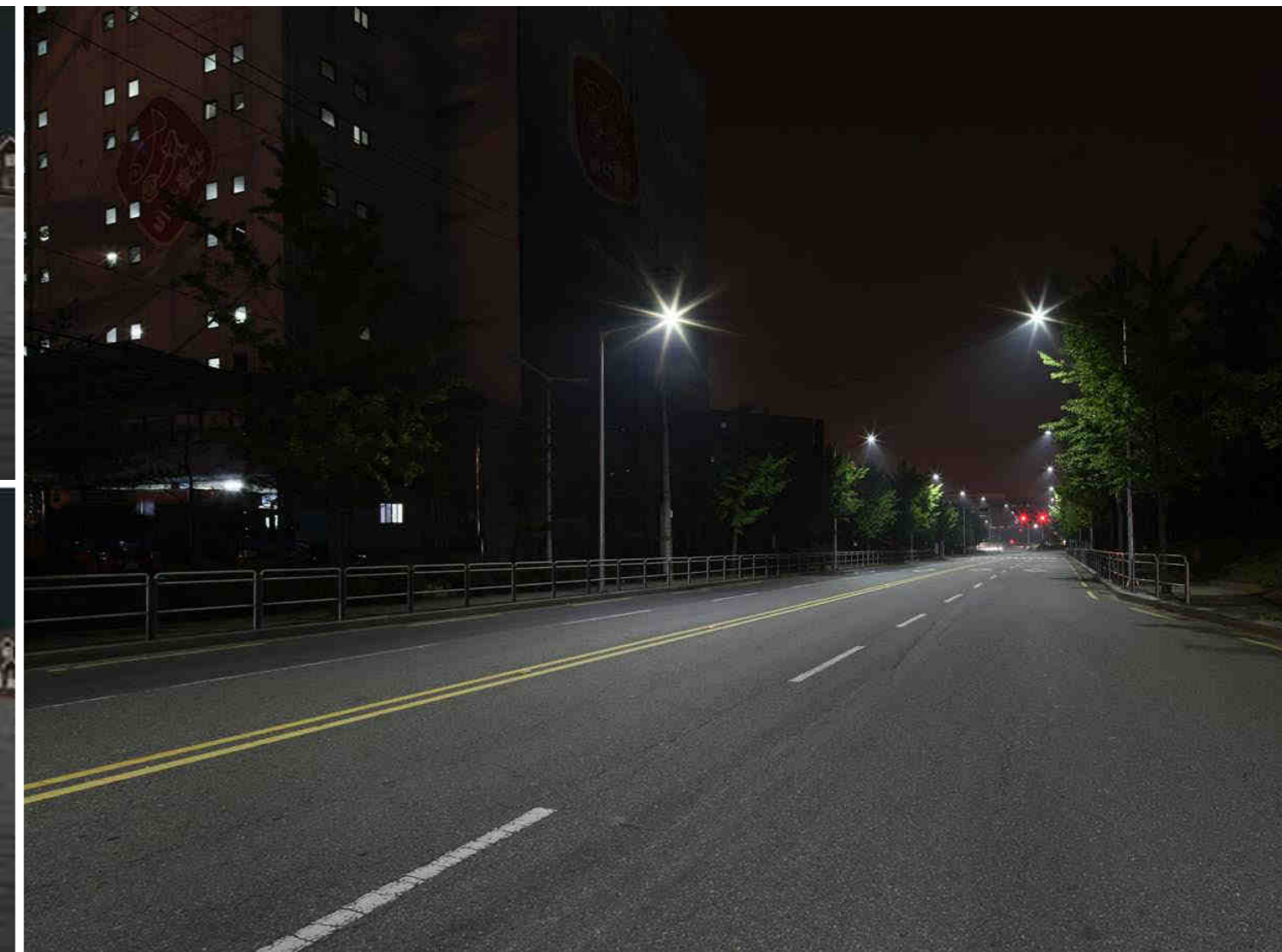

Theme 04

Heal

The power of light to influence mind and body states in being harnessed in products and spaces. By controlling light color, intensity and design, we are now able to sync natural biometric rhythms and improve the health and wellbeing of inhabitants.

Responsive walls in hospitals for positive distraction in children ▶

Digital patterns in the Nature Trail along the corridor of the Great Ormond Street Hospital in London soothe and engage kids on their way to the anesthesia room. This installation covers a 50m stretch and is made of 72,000 interactive lights embedded at various levels. The wall comes to life with patterns of animated animals on detecting movement. This lively interaction makes the journey down to the anesthesia room a little easier for kids of all ages.

Installation: The Nature Trail, Jason Bruges Studio

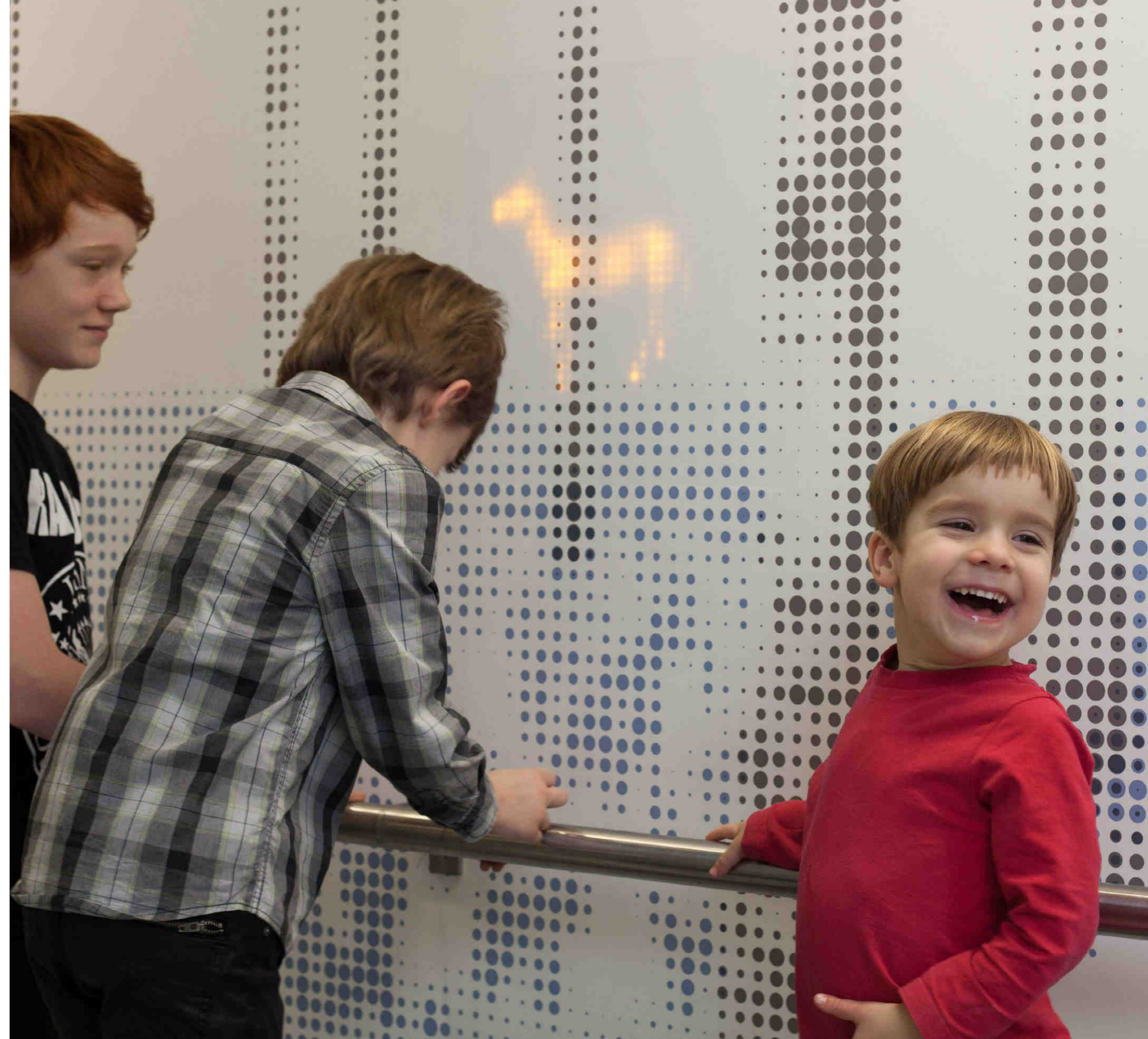



Light therapy at bus stops fight the winter blues

30 bus stops in Sweden have special light panels installed to help combat Seasonal Affective disorder, brought on by a lack of sunlight during winter months. Developed as part of an advertising campaign, the light panels work best if commuters stand in front of them for 30 minutes with their eyes open.

Installation: Umea



Light recipes for a bountiful crop

LEDs can be finely tuned to provide optimized 'light recipes' at every stage of a plant's growth. When applied to horticulture, this solution can increase yields, quicken flowering and enhance root growth, germination and overall health and growth of plants. Additionally, the low heat map and power consumption provide savings of space and power consumption!



05

Communicate

On when you need it and off when you don't, light is being used to create temporary demarcations and flexible environments. With these lighting experiences, designers are reimagining the ways in which a space can be used.

Change court lines at the flick of a switch ▶

The ASB Glassfloor uses hidden LEDs to switch between different court markings for different sports at the touch of a button. The embedded LEDs enhance the experience for spectators by displaying score, statistics and team colors directly on the playing surface. This flexible floor is at the heart of a multi-purpose gymnasiums.

Installation: ASB Systembau

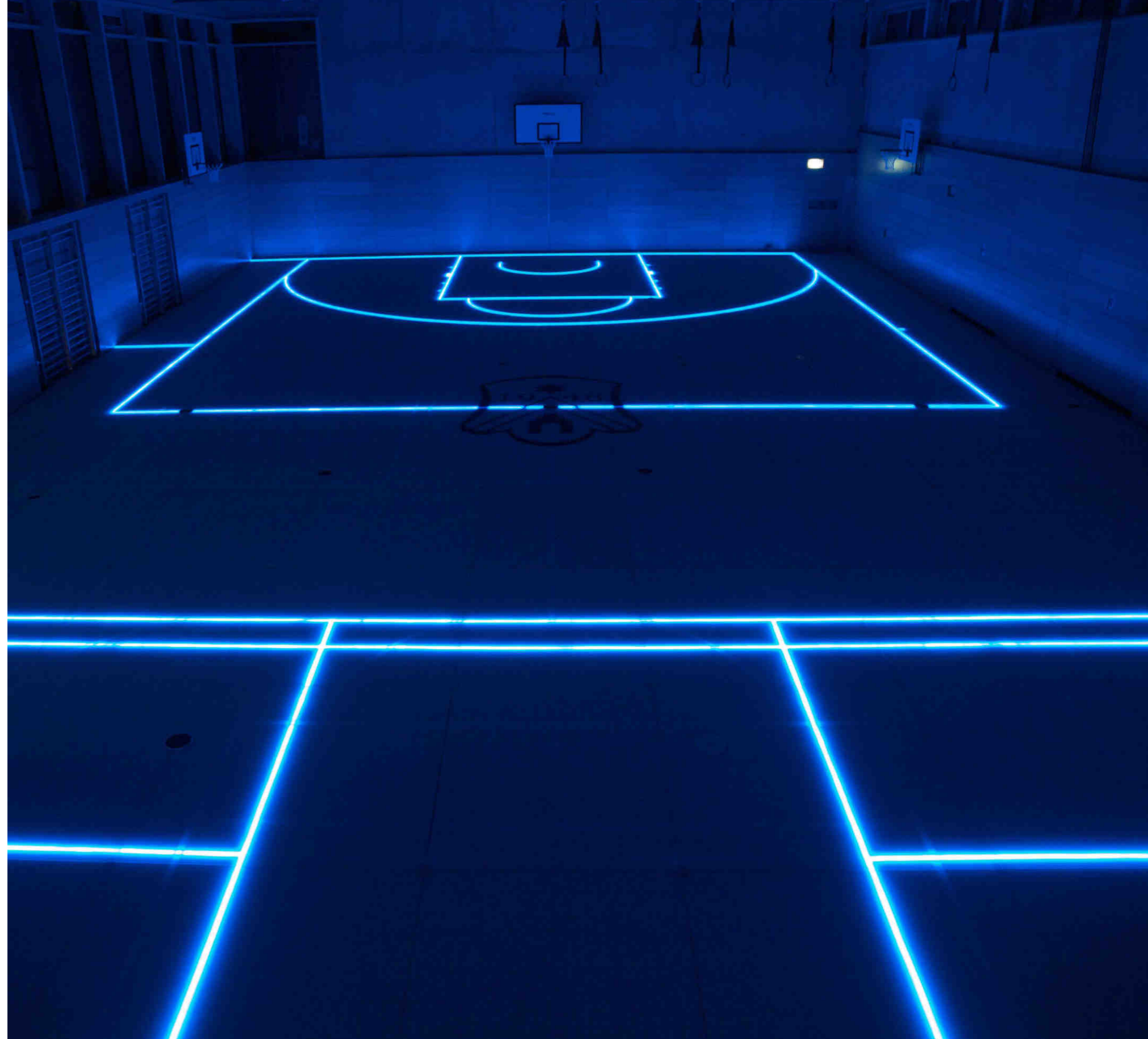

Networked lamps to keep you in sync with loved ones

The Good Night Lamp is a set of small links interlinked to a large lamp. The lamps are distributed among people who want to stay in touch. If the owner of the large lamp switches it off, the light on the smaller lamps is also switched off, telling the linked circle the person has gone to bed or office, etc. It also acts as a handy way to stay coordinated with friends and family across time zones.



Light projections to keep on road cyclists safe at night

Bike safety company XFire has created a lighting system to make bikers more visible to traffic at night. The XFire Bike Lane is a safety light that includes flashing red LED lights, along with red lasers that project onto the road to create an instant bike lane. This lane is visible over a mile away and is clear under headlights and streetlights. The handy gadget is weather and shock-proof and is easy to attach on any bike.

Installation: Xfire

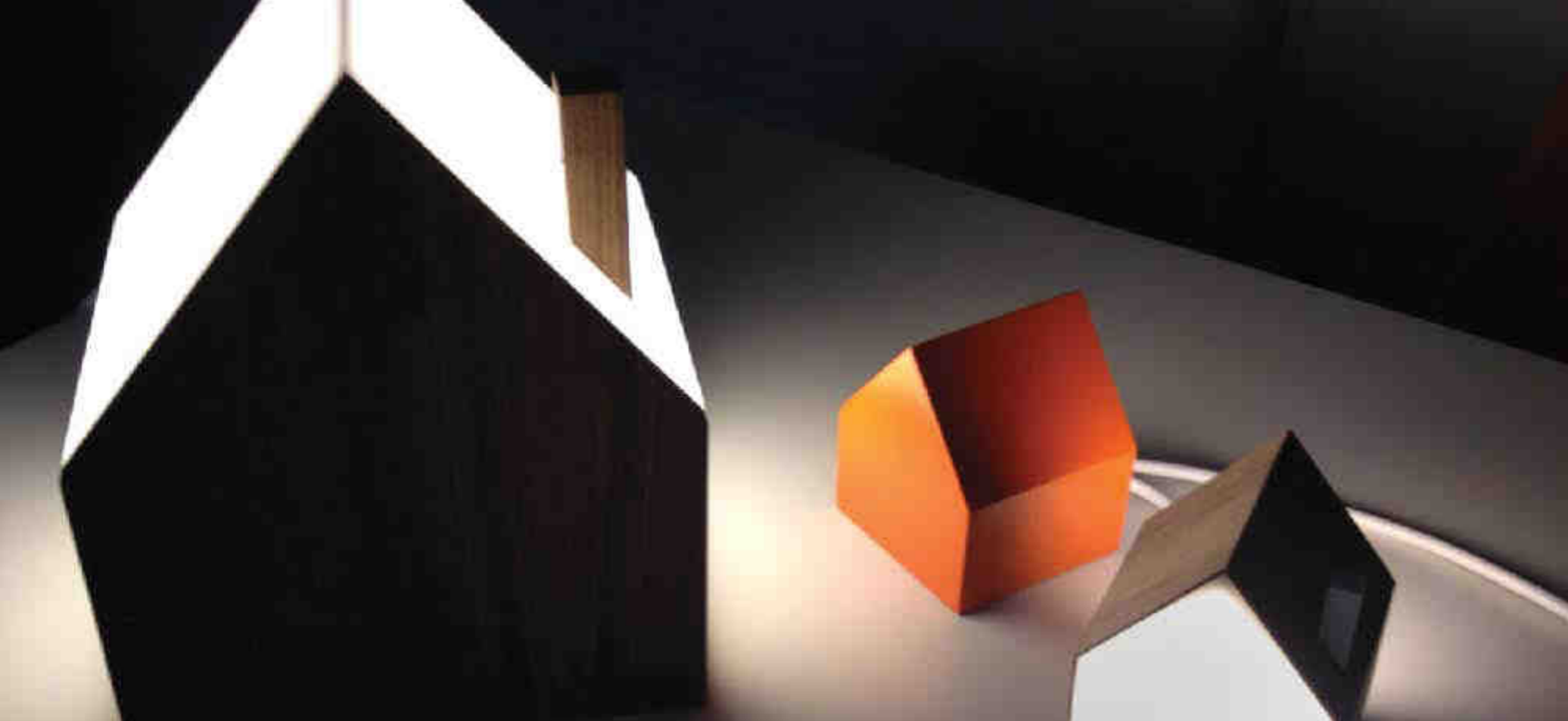

06

Empower

By exploring new methods for capturing and repurposing resources at hand, light is becoming accessible to everyone. Increasingly, systems use alternative sources of energy to power sustainable, low-cost lighting solutions, creating new opportunities for people living with limited resources.

Solar suitcase provides light to health workers when they need it the most

WE CARE Solar is an organization working to bring the most basic and important technology to hospitals in developing nations. Their first such initiative is an off-grid, Solar Suitcase system that includes high-efficiency LED lights, a universal cell phone charger, a charger for AA or AAA batteries, and 12V DC outlets. The case supports 40W or 80W solar panels, and stores energy in a 12 amp-hour sealed lead-acid battery.

Installation: Dr. Laura Stachel and Hal Aronson,





Gravity powered lamps bring light to developing communities

GravityLight is an innovative lamp that is powered by adding weight to a mesh bag hanging below the device. As gravity causes the weight to descend, the lamps generates thirty minutes of light. The device is recharged by simply returning the weight to its original position, starting the process again. The charging can be adapted to power electronics such as radios and batteries. GravityLight has no batteries to run out, replace or dispose of, creating a completely clean alternative to conventional energy sources.

Installation: deciwatt.org



Community spaces that **light up with life after the sun goes down**

Philips Lighting is building more than 100 solar powered community Light Centers throughout Africa, creating well-lit community areas that people can use after the sun goes down. The Light Center covers an area the size of a small soccer pitch, and is lit with solar-powered LED lights. Local authorities can provide for night-time sports, evening education and community events, all while creating additional revenue. The long life batteries need to be replaced every 4-5 years, creating a sustainable and low cost light source.



We collaborate to
transform
lives with light

We invest in research and collaborate with creative minds to craft innovations that matter to people today and tomorrow. Together we transform environments, create experiences, shape identities and change futures.



We understand that

getting **right light**
is an art, and

a whole lot
of science,
that delivers
quality light.



Light when combined with beautiful design

creates experiences
that **make each
day special.**



Choose the right LED

When purchasing LED lighting there are certain questions you should ask to ensure you get the best quality and the right product for your application. Here are some key questions that will help you select LED products and solutions fit for you.

01 How is the lifetime of a LED measured?

With an LED source light output diminishes over time. Lifetime typically refers to the useful life of the light output (also referred to as lumen maintenance). The lifetime of a white LED is the time till which at least 70% of the original light output remains.

02 Does the quoted lifetime include the electronics and other components necessary to drive the LED source?

Under the right conditions LEDs can operate for very long periods of time, however it is important that the supporting components used in the fixture design also have long lifetimes and are of high quality.

03 What is the maximum ambient temperature under which the fixture can operate and achieve rated life?

The lifetime numbers for many fixtures are quoted at room temperature. It is important to know the extreme end of the quoted operating temperature range.

04 Does the fixture design have any special features for heat sinking/thermal management?

Thermal management plays an integral part in the life of LED sources and is directly affected by the fixture design. Heat must be properly drawn away from LED sources in order to maximize product lifetime. This can be achieved through an appropriately designed heat sink.

05 What warranty is offered?

A documented, clear definition of the warranty terms for the product is more useful rather than vague terms like 'guaranteed'.

06 If multiple white light fixtures are used on a project, are color points among them adequately matched?

The tint or hue of white LEDs may change from batch to batch due to inherent variations that occur in all semiconductor fabrication processes which ensures consistent color performance from fixture to fixture.

07 How do optics affect system efficiency?

Beam shaping optics such as reflectors and cover lenses can have a dramatic effect on the performance of a fixture. Performance claims must include information on all relevant system components. Photometric data helps in judging the performance.

08 Does the proposal for a job include all the components needed to operate the LED fixtures?

Many LED fixtures require external transformers and other controls in order to achieve a functional installation. Be sure to include all of these components in the project budget.



Why **Philips** LED lighting?

Philips has been designing, developing and manufacturing LED lighting products resulting in a far reaching intellectual property portfolio and more than 20,000 time-tested installations. We have strengthened our leadership position and revenue generation in the LED Lighting market with solutions across segments like indoor, outdoor, railways, and street lighting. We are leaders in technology and product performance in the LED lighting industry and are a confident choice of lighting specifiers across the globe.

Performance

Lifetime & reliability

Philips applies best known methods for handling issues associated with thermal management (source lifetime), optics (beam uniformity, quality and output), energy management (high energy efficiency, low power consumption) and ease of installation (contractor friendly) to deliver industry leading results.

Color consistency and light quality

Optibin[®], our proprietary production binning optimization process, ensures consistent performance from fixture to fixture. Our strategic relationships with the leading LED source suppliers also give us access to the best LED source binning and source performance. As a result, our LED lighting products generate the truest color and the best light intensity.

Deliver required specifications

By virtue of our close collaboration with standards and regulatory agencies, today we are leading the way to develop and introduce standards for LED lighting products. Our products are tested in accordance with industry standards at accredited laboratories.

Uniform beam quality

Philips' optics expertise gained from over a decade of LED lighting product development enables all our products to deliver uniform beam quality, with no hot spots or unevenness, ensuring optimal light distribution.

Quality

Validation and testing

Philips performs extensive validation and environmental testing using accredited facilities to ensure product quality. Rigorous tests include thermal cycling, humidity, and water immersion to verify the functionality and robustness of products under various extreme environmental conditions.

Complete system approach

Philips designs, develops, and manufactures complete system solutions: everything needed to power up and control intelligent LED illumination. This approach assures that the entire system is optimized to work together and meets regulatory compliance as well as provides a high level of flexibility in the system.

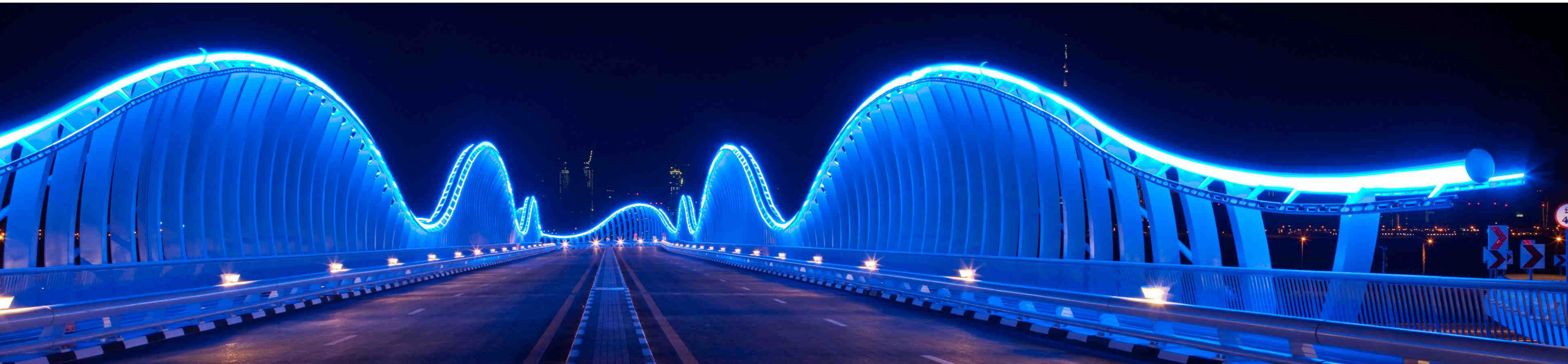

Signature
lighting collection

A selection of products to transform your vision into reality.

Find. Choose. Pick.

Signature

lighting Collection



48
Indoor lighting



134
Outdoor lighting



184
LED lamps



198
Architectural lighting



212
Home lighting



224
Lighting controls

Beam angles



Symmetric



Asymmetric



Narrow beam



Medium beam



Wide beam



Double asymmetric



Direct



Direct/indirect

Mounting types



Suspended



Wall



Surface



Recessed



Table



Floor



Pole



Indoor lighting

Page No.	Product	Mounting type
50	Arcus	Surface, Suspended
56	BoldPlay	Suspended, Wall
62	Chopstick	Suspended, Wall
68	CoreView	Recessed
74	CoreLine Proset	Recessed
80	DayWave	Suspended
86	DayZone	Recessed
92	eW downlight	Surface
98	Jump	Suspended
104	Lumistone	Suspended
110	LuxSpace	Recessed
116	Rotaris	Suspended, Recessed
122	StyliD	Surface (Track mount)
128	TruGroove	Recessed



Arcus

Arcus is a technologically advanced modular LED bar light which is available in two lengths: 2ft and 4ft. It has options of 'X' / 'L' / 'T' and linear connectors, which provide creative freedom to design spaces with lighting. It can be mounted 'on-surface' or 'suspended' as per application requirement. Arcus is suitable for applications like common and breakout areas in offices, canteens, retail spaces (both medium and big formats) and sales counters.



Recommended applications

Open office areas

Selling floors

Private offices

Innovate with light

Modular

With extendable ends and angular clips, Arcus offers incredible flexibility. Be it linear form, multiple angles or shapes, you can personalize as you desire.

Adaptable

This product has additional advantage of multiple mounting which compliment your interiors with suspended or surfaced mounting.

Glare free light

Arcus offers light management through inbuilt prismatic reflector which results in wide distribution of light. It also means more area is uniformly lit with less number of lights.



Product features:

- Offers freedom to design your ceiling with multiple mounting options
- Highly efficient and glare free
- Endless design possibilities with different deco end cap and deco piece options





Arcus

Technical specifications

Luminaire

Type	Arcus 4ft, 2ft
Beam angle	Wide beam
Installation/mounting type	Surface, Suspended
Color Temperature Tc (K)	4000 / 5000
Color Rendering Index (Ra)	80
Housing (Material And Finish)	Die-cast aluminum
System Wattage (W)	27
System Voltage (V)	220-240 / 50-60 Hz
System Lumen Package (lumen)	2000
System Efficacy (lm/W)	75

Dimmable/Non Dimmable	Dimmable
Classifications (IP/IK)	IP20
Optical System	High Efficiency Diffuser
Cover (Glass/ PC)	Acrylic
Life in hours (@ L70)	Upto 40,000
Electrical Class	Class I
Driver	
Driver Type	Integrated
Operating Voltage (V)	220-240
Surge Protection	As per relevant IS standard only

Dimensional drawing

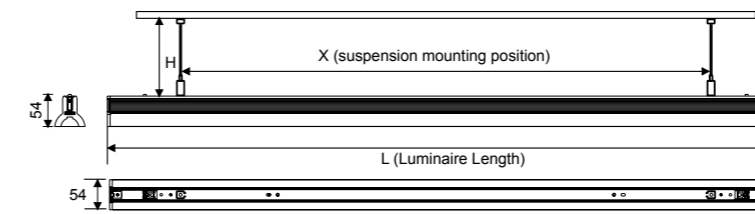

Photometric data

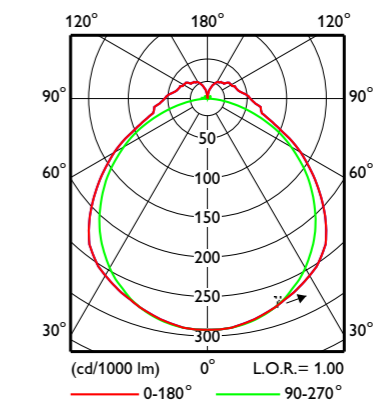



BoldPlay

Brilliant design and intuitive engineering fearlessly combine to deliver unprecedented performance. BoldPlay's striking contrast of effortless style and urban edginess makes a distinct statement in any space.



Recommended applications

Open office areas

Meeting rooms

Executive cabins



Effortless style and contrast

Extraordinary

LED luminaire with MesoOptics, light guide technology and brilliant design and engineering offering exceptional control, true color rendition, and perfect uniformity with sculpted contours, sleek high gloss, and minimalist form.

Modern design

Offered in a palette of color temperatures that render true, natural and vibrant. It also integrates response daylight sensors and Airwave wireless controls to maximize energy savings.

Energy savings

Its direct indirect distribution enables ultra wide row spacing, reducing the number of luminaires required in a space.



Variants >

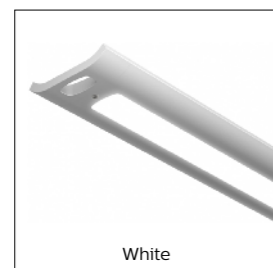

White



Black



Titanium

Product features:

- Uniform lighting levels
- Allows wider row spacing
- Glare-free illumination





BoldPlay

Technical specifications

Luminaire

Type	7806 family	Dimmable/Non Dimmable	Dimmable
Beam angle	NA	Classifications (IP/IK)	IP40
Installation/mounting type	Suspended, Wall mounted	Optical System	MesoOptics
Color Temperature Tc (K)	3000 / 3500 / 4000	Cover (Glass/ PC)	NA
Color Rendering Index (Ra)	84	Life in hours (@ L70)	Upto 60,000
Housing (Material And Finish)	Made of premium material	Electrical Class	Class II
System Wattage (W)	47/ 32	Driver	
System Voltage (V)	220-240 / 50-60 Hz	Driver Type	Integrated
System Lumen Package (lumens)	4800 / 3400	Operating Voltage (V)	220-240
System Efficacy (lm/W)	Upto 106	Surge Protection	As per relevant IS standard only

Dimensional drawing

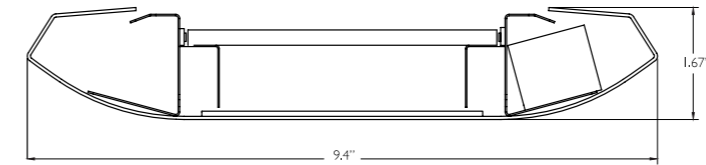

Photometric data

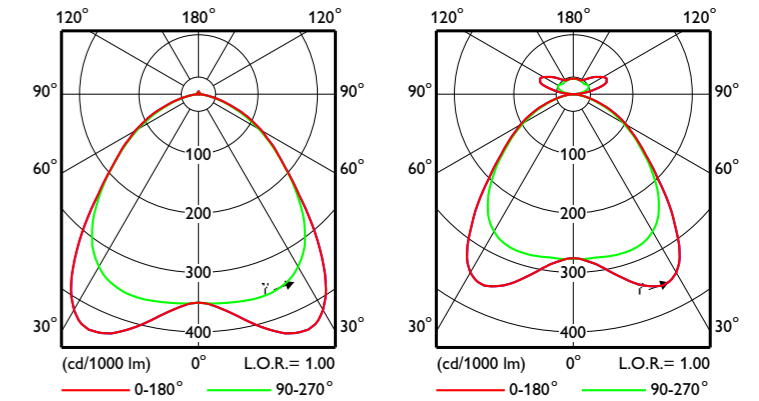



Chopstick

Chopstick offers small size with big lighting performance and a price point that makes it ideal to use in many different types of spaces.



Recommended applications

Open office areas

Meeting rooms

Executive cabins

Balance of light, form and materials

Small size, big performance

More uniform luminous environments with optimal energy-efficiency. Chopstick's minimalist design is now available in LED options, in addition to T5 and T5HO lamping options.

Suspended and wall mount versions

Available in suspended and complementary wall mount versions, Chopstick allows designers to achieve a consistently clean and simple look throughout a space.

Clean, crisp and simple

Chopstick is a great solution for achieving clean lines, minimalist details, luminous elements and want to provide maximized lighting quality within a space.

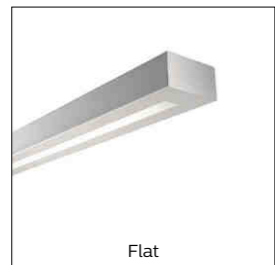

Flat

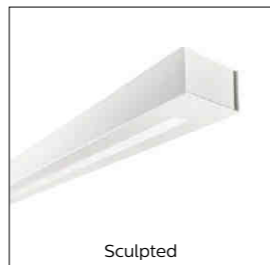

Sculpted

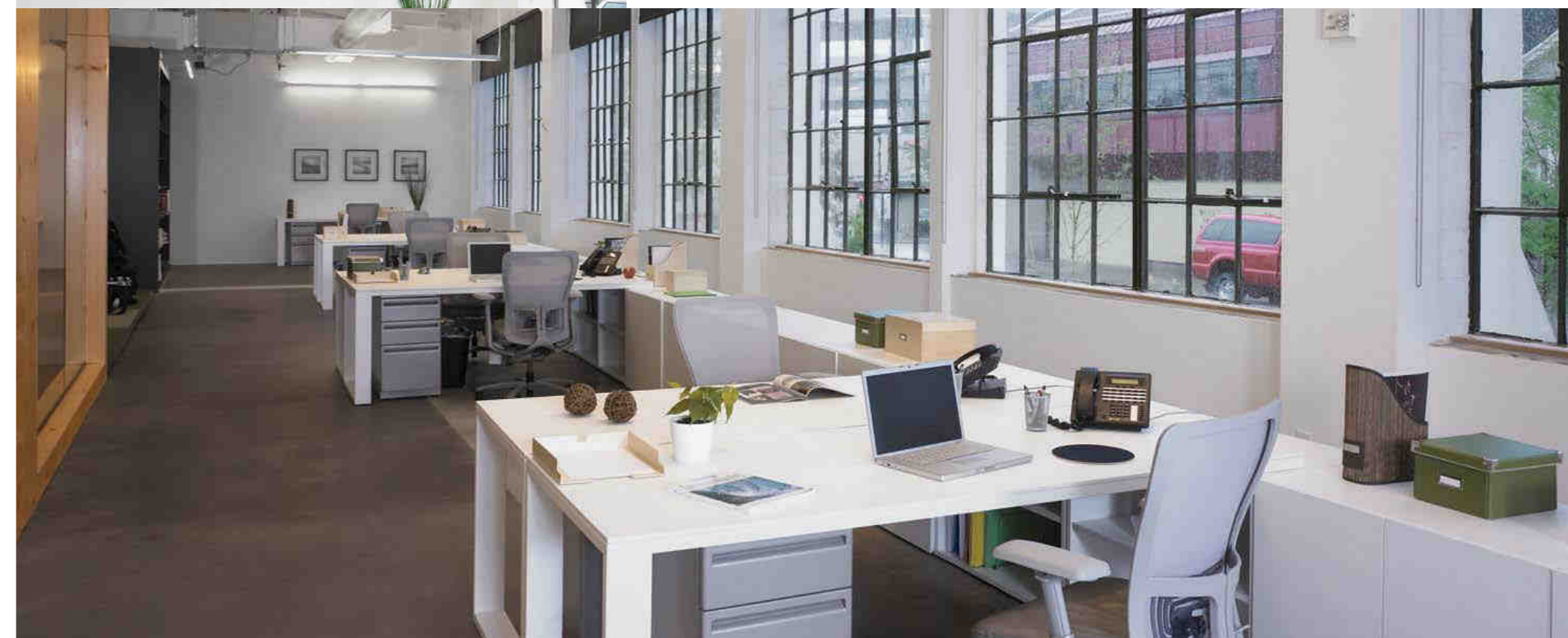

Product features:

- Wide-spread lighting distribution
- Efficacy up to 108lm/W
- Available in 4ft and 8ft modules





Chopstick

Technical specifications

Luminaire

Type	7505	Dimmable/Non Dimmable	Dimmable
Beam angle	Direct/indirect	Classifications (IP/IK)	IP20
Installation/mounting type	Suspended, wall mounted	Optical System	MesoOptics
Color Temperature Tc (K)	3000 / 3500 / 4000	Cover (Glass/ PC)	NA
Color Rendering Index (Ra)	>80	Life in hours (@ L70)	Upto 50,000
Housing (Material And Finish)	20 gauge cold-rolled steel precision formed	Electrical Class	Class I
System Wattage (W)	47/ 32		
System Voltage (V)	220-240 / 50-60 Hz	Driver	
System Lumen Package (lumens)	4800 / 3400	Driver Type	Electronic
System Efficacy (lm/W)	108 lm/W	Operating Voltage (V)	220-240
		Surge Protection	NA

Dimensional drawing



Photometric data

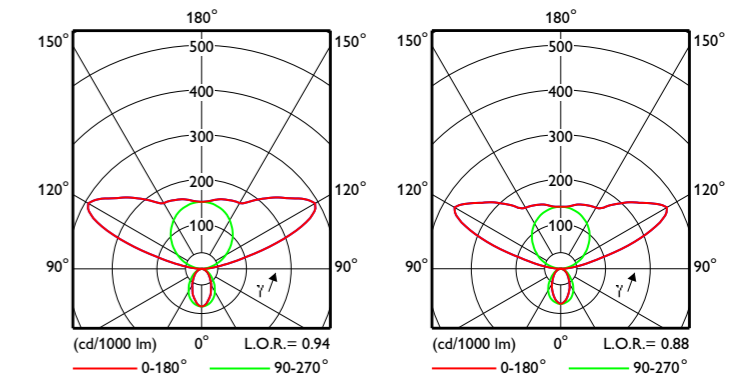



CoreView

CoreView is a functional LED based luminaire for general lighting in offices. Its modern design has emotional appeal, creating a forward-looking advanced impression. Its best-in-class LED technology offers considerable savings on energy costs while delivering the required light output.



Sustainable and efficient

Sustainable solution

Replaceable LED module allows upgrading anytime in the future.

Energy saving

High energy saving and reduction in CO2 emissions.

Visual comfort

Indirect lighting enhances visual comfort of the working environment without compromising on light quality or efficiency.

Variants >

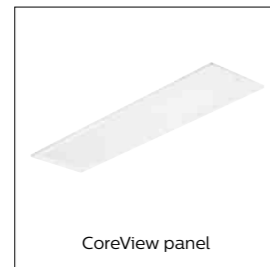

Recommended applications

Open office areas

Meeting rooms

Selling floors



Product features:

- Slim, attractive form factor
- RoHS-compliant and mercury-free
- Indirect lighting without sacrificing light quality



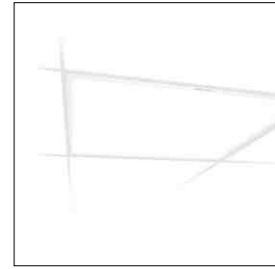

CoreView

Technical specifications

Luminaire

Type	RC165V/RC166V	Dimmable/Non Dimmable	Dimmable
Beam angle	110°	Classifications (IP/IK)	IP20
Installation/mounting type	Recessed	Optical System	PMMA
Color Temperature Tc (K)	3000 / 4000	Cover (Glass/ PC)	Glass
Color Rendering Index (Ra)	>80	Life in hours (@ L70)	Upto 40,000
Housing (Material And Finish)	High-quality steel	Electrical Class	Class I
System Wattage (W)	41	Driver	
System Voltage (V)	230-240 / 50-60 Hz	Driver Type	Integrated
System Lumen Package (lumens)	3400	Operating Voltage (V)	220-240
System Efficacy (lm/W)	80	Surge Protection	As per relevant IS standard only

Dimensional drawing

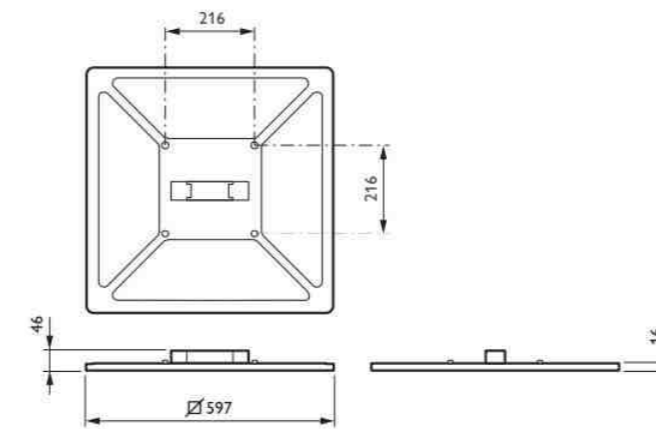

Photometric data

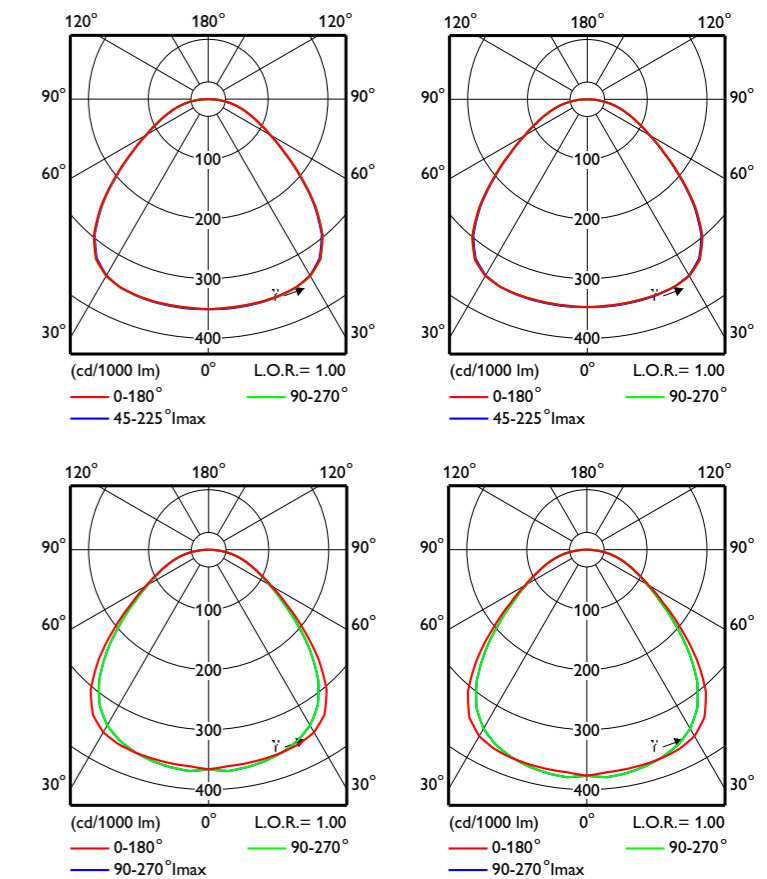

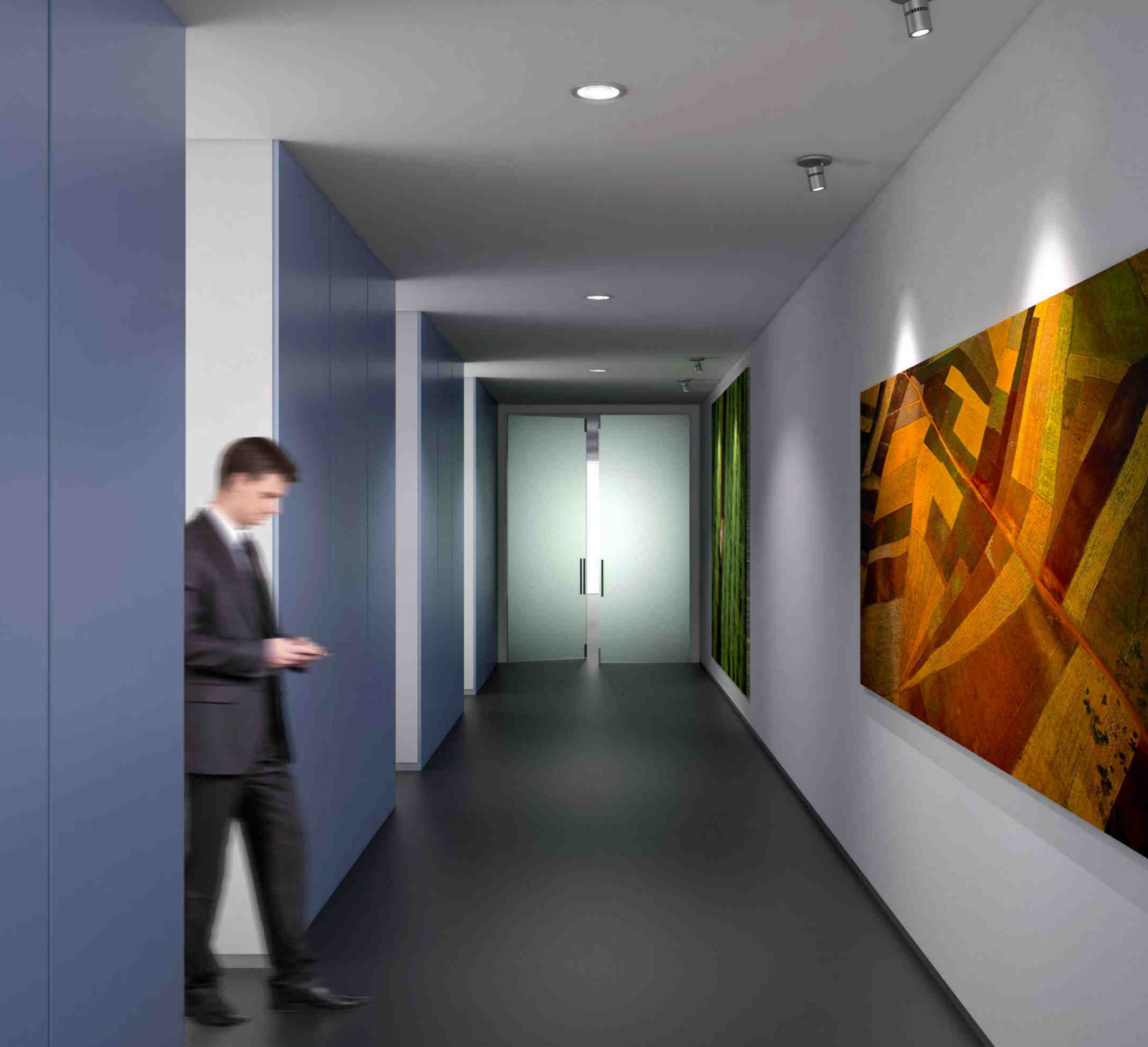

CoreLine ProSet

CoreLine ProSet is a dimmable LED downlight available in fixed and adjustable versions. It delivers very substantial energy savings compared to a luminaire equipped with an equivalent halogen lamp. Installation is easy, as there is no need for a separate driver.



Efficient and versatile

Dimmable

The fixture is easily dimmable which helps creating a varied lighting environment and at the same time offers energy efficiency.

Varied solutions

It is available in fixed and adjustable versions with a choice of white tones and beam angles.

Easy switch to LED

Easy installation with 10 times longer life and better light output.

Variants >



Recommended applications

Open office areas

Selling floors

Reception and corridors



Product features:

- Dimmable
- Choice of color temperatures: 3000 and 4000K
- Choice of beam angles: 25° and 40°





CoreLine ProSet

Technical specifications

Luminaire

Type	RS120B, RS121B	Dimmable/Non Dimmable	Dimmable
Beam angle	25° or 40°	Classifications (IP/IK)	IP44
Installation/mounting type	Recessed	Optical System	NB / MB
Color Temperature Tc (K)	3000 / 4000	Cover (Glass/ PC)	Clear acrylic
Color Rendering Index (Ra)	>80	Life in hours (@ L70)	Upto 30,000
Housing (Material And Finish)	Die-cast aluminum	Electrical Class	Class I
System Wattage (W)	13		
System Voltage (V)	230-240 / 50-60 Hz	Driver	
System Lumen Package (lumens)	640	Driver Type	Integrated
System Efficacy (lm/W)	50	Operating Voltage (V)	220-240
		Surge Protection	As per relevant IS standard only

Dimensional drawing

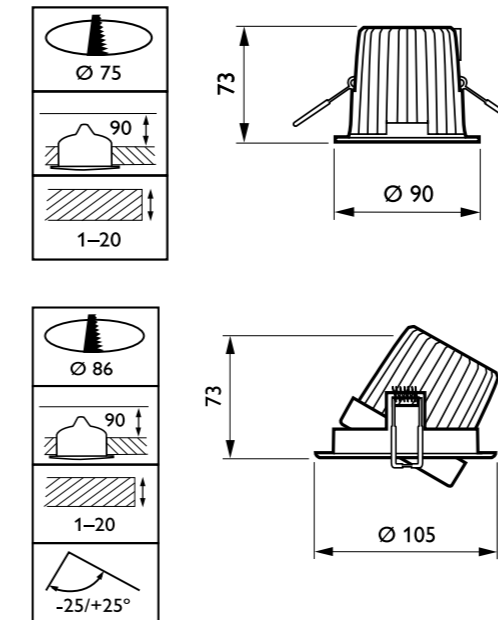

Photometric data

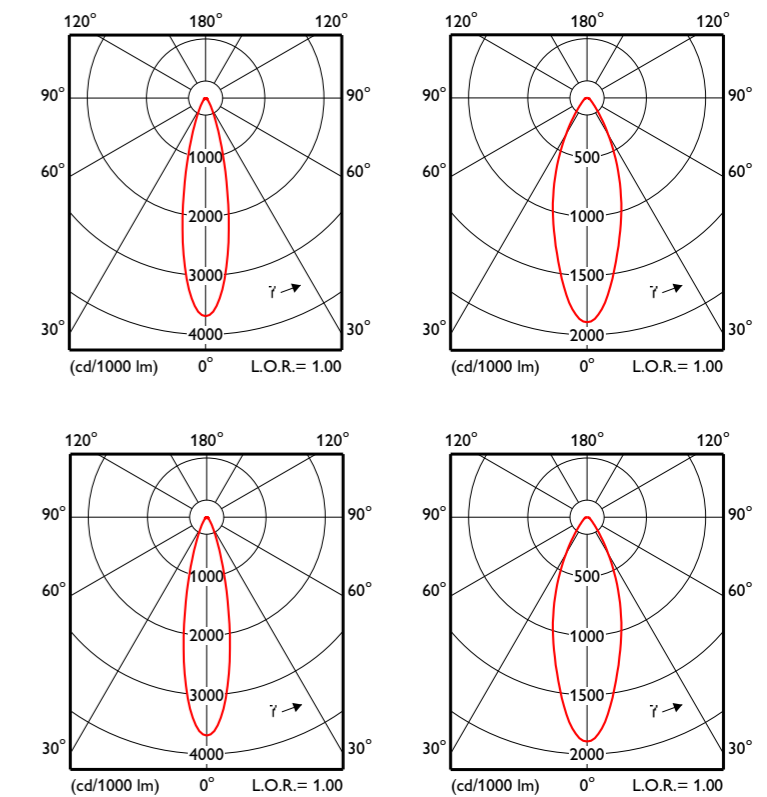



DayWave

With its graceful curves and ultra-slim housing, DayWave has an innovative design language of its own. It is the world's first LED-enabled luminaire for office lighting, meeting the requirements for visual comfort.



Recommended applications

Open office areas

Meeting rooms

Reception desks

Unique design, uniquely inspiring.

Design to inspire

Breakthrough and unique design: soft lines and ultra slim shapes can be easily connected into lines and patterns enhancing well being by bringing the rhythm of the day into the office. Homogeneous light distribution thanks to a breakthrough optic design.

Dynamic light

Ambience creation through LED lighting - ever - changing atmospheres. DayWave creates an inspiring natural ambience that enhances employees' sense of wellbeing. It brings the dynamic rhythm of daylight into the office, subtly shifting between cool and warm light over the course of the day.

Variants >



BPS800 3000-5500 H-DN



BPS800 3000-5500 H-DN



Product features:

- Breakthrough and unique design
- Consistent light output
- Long life of 50000* hours





DayWave

Technical specifications

Luminaire

Type	BPS800	Dimmable/Non Dimmable	Dimmable
Beam angle	NA	Classifications (IP/IK)	IP20
Installation/mounting type	Suspended	Optical System	Micro-lens-optics
Color Temperature Tc (K)	3000 - 6500	Cover (Glass/ PC)	Clear Acrylic
Color Rendering Index –Ra	>80	Life in hours (@ L70)	Upto 50,000
Housing (Material And Finish)	Extruded anodised aluminium, finishing brushed (BRU)	Electrical Class	Class I
System Wattage (W)	130	Driver	
System Voltage (V)	220-240 / 50-60 Hz	Driver Type	PSR [Power supply unit regulating
System Lumen Package (lumens)	3400 - 4900	Operating Voltage (V)	220-240
System Efficacy (lm/W)	As per variant	Surge Protection	As per relevant IS standard only

Dimensional drawing

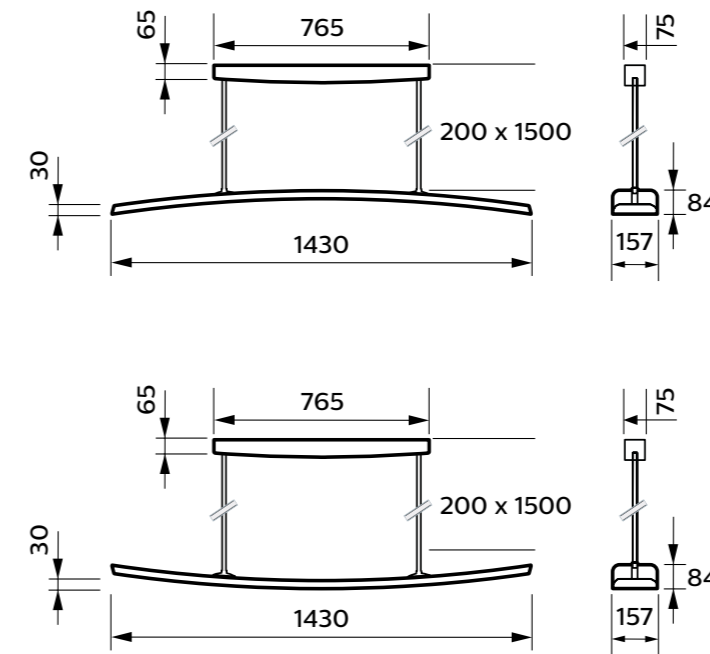

Photometric data

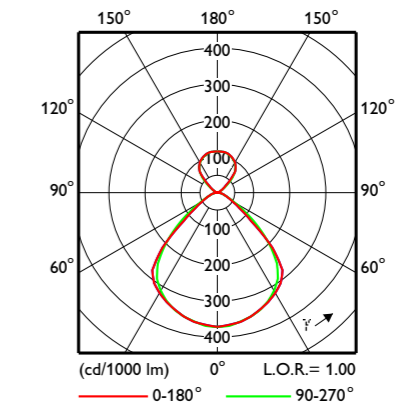



DayZone

For office lighting, customers want to capture the benefits of LED technology. DayZone offers – sustainable and fresh, high impact design, without compromising visual comfort. It is available in square versions and, to ensure a better fit in plaster ceiling applications, in a round housing.



Recommended applications

Open office areas

Meeting rooms

Conference rooms



Innovative design meets sustainability

Inspiring design

A luminaire that breaks away from fluorescent lighting designs of the past to offer a striking appearance and light effect.

Sustainable solution

Delivers high-quality functional lighting with an energy efficiency that matches or even outperforms traditional fluorescent systems.

Visual comfort

DayZone really shines with its impressive visual comfort. Glare control and color consistency are compliant with future office norms.

Variants >



BBS560



BBS561



BBS562



BBS567

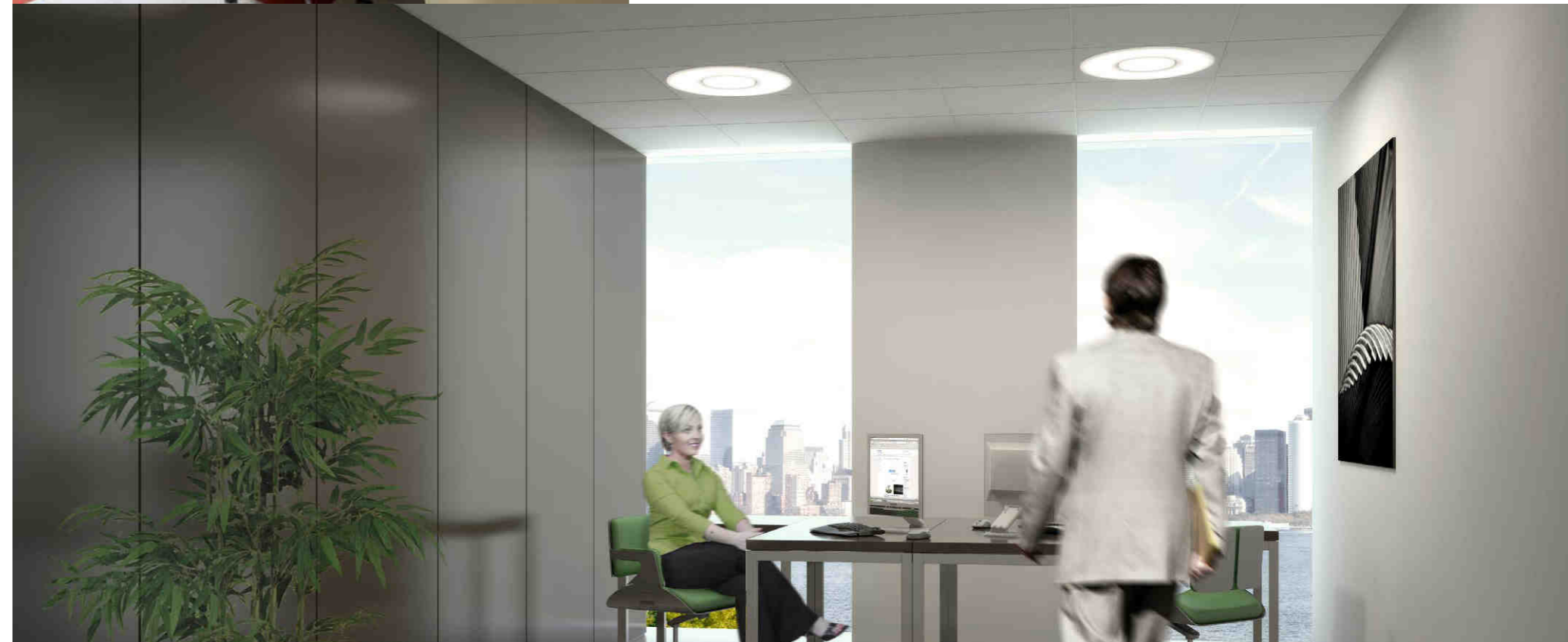

Product features:

- Dedicated MLO optic design
- Special patented light-mixing chamber
- Round housing available for plaster ceiling



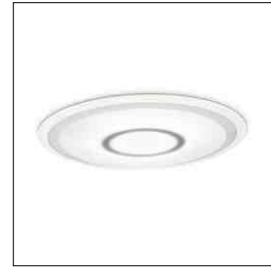

DayZone

Technical specifications

Luminaire

Type	BBS560 (module size: 600 mm) BBS562 (module size: 625 mm) BBS567 (module size: 675 mm) BBS561 (round housing)	Dimmable/Non Dimmable	Dimmable
Beam angle	90°	Classifications (IP/IK)	IP20
Installation/mounting type	Recessed	Optical System	Acrylic (AC-MLO), polycarbonate (PC-MLO)
Color Temperature Tc (K)	4000 K: 51 W (LED35S) 3000 K: 55 W (LED35S)	Cover (Glass/ PC)	Clear Acrylic
Color Rendering Index (Ra)	80	Life in hours (@ L70)	Upto 50,000
Housing (Material And Finish)	Zinc-coated steel	Electrical Class	Class I
System Wattage (W)	51 / 55	Driver	
System Voltage (V)	220-240 / 50-60 Hz	Driver Type	Integrated
System Lumen Package (lumens)	3500	Operating Voltage (V)	220-240
System Efficacy (lm/W)	Upto 70	Surge Protection	As per relevant IS standard only

Dimensional drawing

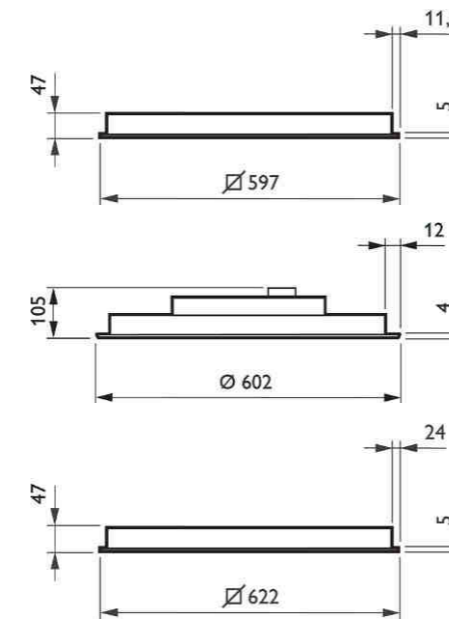

Photometric data

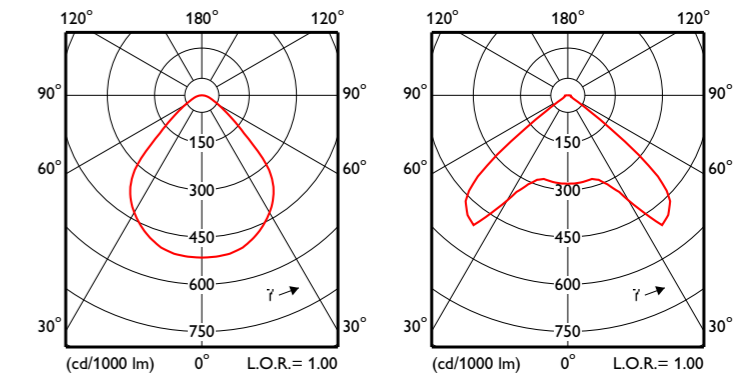



eW downlight

This easy-to-install, dimmable downlight is ideally suited for lobbies, corridors, elevators, conference rooms, common spaces, kitchenettes, and interiors in commercial, hospitality, retail, and residential environments. With its unobtrusive, sleek design, eW Downlight Powercore is especially appropriate where recessed installation is not possible.



Recommended applications

Open offices

Hospitality areas

Selling floors



Energy-efficient LED downlight

Energy efficient

Integrated Powercore technology ensures rapid, efficient and accurate control of power output to the fixture directly from line voltage, eliminating the need for remote transformers or other external power supplies.

High-quality light

eW downlight Powercore is a low-profile, surface-mounted LED downlight providing high quality illumination.

Easy to install

Use of standard wiring dramatically simplifies installation and helps lower total system cost.



Variants >



BCS401



BCS402

Product features:

- Revolutionary thermal management system
- Dimming capability
- Long life of 85,000 hours

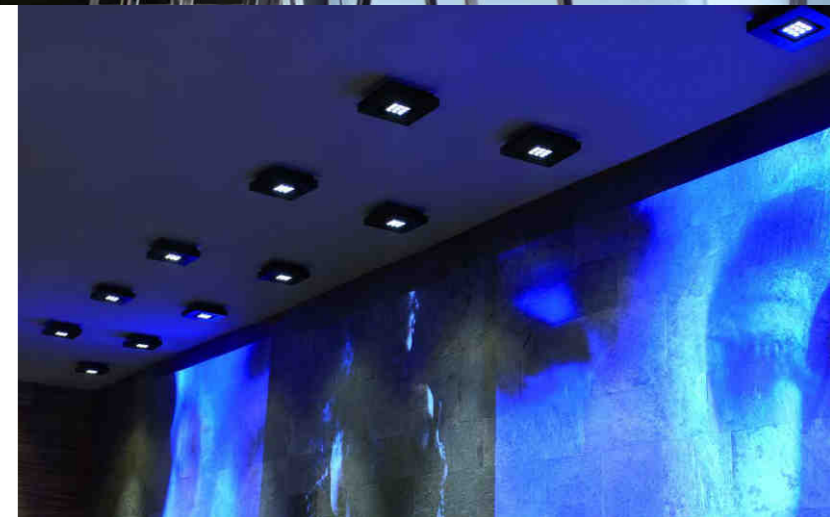



eW downlight

Technical specifications

Luminaire

Type	BCS401, BCS402	Dimmable/Non Dimmable	Dimmable
Beam angle	30° / 65°	Classifications (IP/IK)	IP20
Installation/mounting type	Surface mounted	Optical System	NA
Color Temperature Tc (K)	2700 / 3000 / 3500 / 4000	Cover (Glass/ PC)	Clear polycarbonate
Color Rendering Index (Ra)	>80	Life in hours (@ L70)	Upto 85,000
Housing (Material And Finish)	Die cast aluminium	Electrical Class	Class I
System Wattage (W)	15		
System Voltage (V)	220-240 / 50-60 Hz	Driver	
System Lumen Package (lumens)	Upto 826	Driver Type	Integrated
System Efficacy (lm/W)	Upto 55	Operating Voltage (V)	220-240
		Surge Protection	As per relevant IS standard only

Dimensional drawing

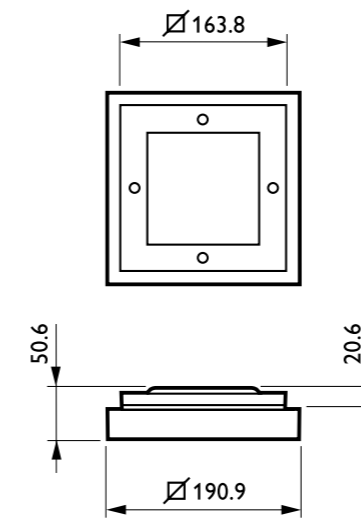

Photometric data

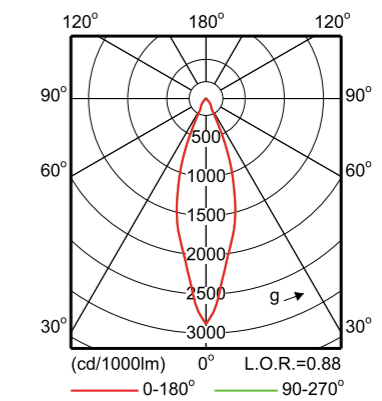

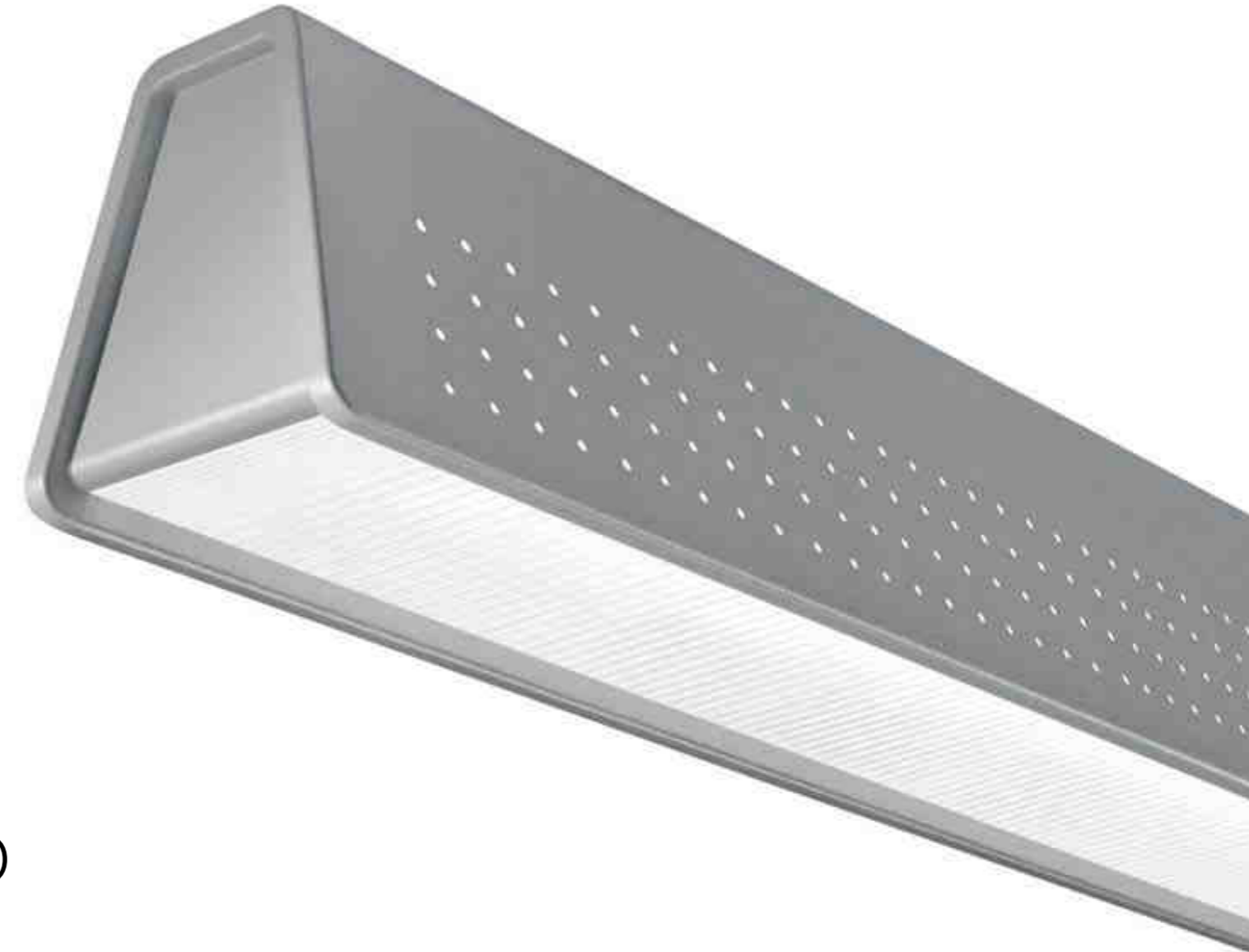

Jump

Soft and sophisticated, free of glare and socket shadows, Jump is an uninterrupted rhythm of playful patterns and subtle textures. Jump's contemporary aesthetic combines the latest lighting technologies with texture, pattern and rhythm along an uninterrupted end to end continuum of luminance.



High performance and flexibility

Design freedom

Limitless combinations of optics and aesthetics gives freedom to construct high performance lighting systems that integrate well with any architectural condition.

Intelligent design

Jump integrates electrical, electronic, optical, thermal and mechanical engineering to deliver optimal light distribution, consistent color and exceptional system performance.

Unparalleled flexibility

Aesthetic design elements, multiple distributions and variable mounting options make Jump a highly flexible choice for functional environments.

Variants >

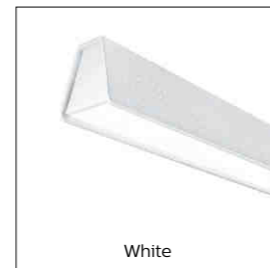

Recommended applications

Open office areas

Meeting rooms

Executive cabins



Product features:

- Integrates with most common T-bar and non-accessible ceiling types
- Comes with factory pre-wired and quick-wire connectors
- Offers numerous standard options for wiring, battery packs and switching





Jump

Technical specifications

Luminaire

Type	1201	Dimmable/Non Dimmable	Dimmable
Beam angle	NA	Classifications (IP/IK)	IP20
Installation/mounting type	Suspended	Optical System	Curved acrylic panel with a layer of protected MesoOptics film
Color Temperature Tc (K)	3000 / 3500 / 4000	Cover (Glass/ PC)	NA
Color Rendering Index (Ra)	>85	Life in hours (@ L70)	Upto 60,000
Housing (Material And Finish)	Made of premium material	Electrical Class	Class II
System Wattage (W)	28 / 45	Driver	
System Voltage (V)	220-240 / 50-60 Hz	Driver Type	Electronic
System Lumen Package (lumens)	2400 / 3600	Operating Voltage (V)	220-240
System Efficacy (lm/W)	>85	Surge Protection	NA

Dimensional drawing

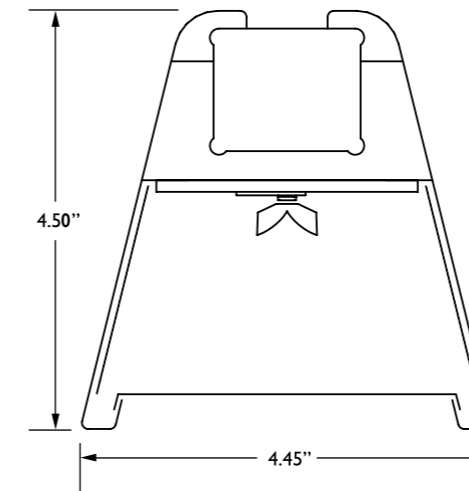

Photometric data

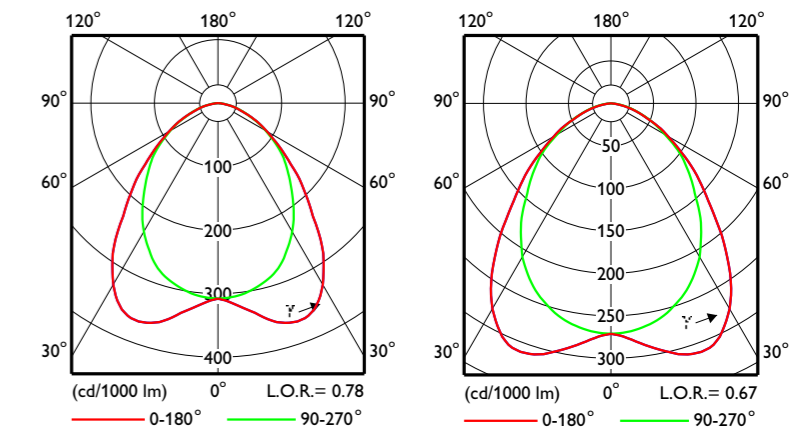



LumiStone

LumiStone is a LED luminaire consisting of two smaller ellipses rather than the traditional single voluminous piece. The ellipses have soft curvatures and resemble smooth stones found in nature. The flexible light effects created with direct and indirect light make LumiStone the perfect choice for inspiring lighting designs.



Recommended applications

Reception desks

Meeting rooms

Executive cabins

Inspiring performance

Appealing design

Lumistone consists of two smaller ellipses with soft curvatures creating a truly inspiring environment with appealing design.

Versatile application

A range of innovative mounting options make LumiStone extremely versatile in application.

Variants >



Product features:

- Choice of direct/indirect lighting
- Long life of 50000 hours
- High color rendering index >80





LumiStone

Technical specifications

Luminaire

Type	SP520P, SP522P, SP524P, SP526P	Dimmable/Non Dimmable	Dimmable
Beam angle	Symmetric	Classifications (IP/IK)	IP20 / 40
Installation/mounting type	Suspended	Optical System	Poly-carbonate LED cup
Color Temperature Tc (K)	3000 / 4000	Cover (Glass/ PC)	NA
Color Rendering Index (Ra)	>80	Life in hours (@ L70)	Upto 50,000
Housing (Material And Finish)	Poly-carbonate	Electrical Class	Class I
System Wattage (W)	29 / 38 / 31 / 40		
System Voltage (V)	220-240 / 50-60 Hz	Driver	
System Lumen Package (lumens)	2000 / 4000	Driver Type	Integrated
System Efficacy (lm/W)	Upto 105	Operating Voltage (V)	220-240
		Surge Protection	NA

Dimensional drawing

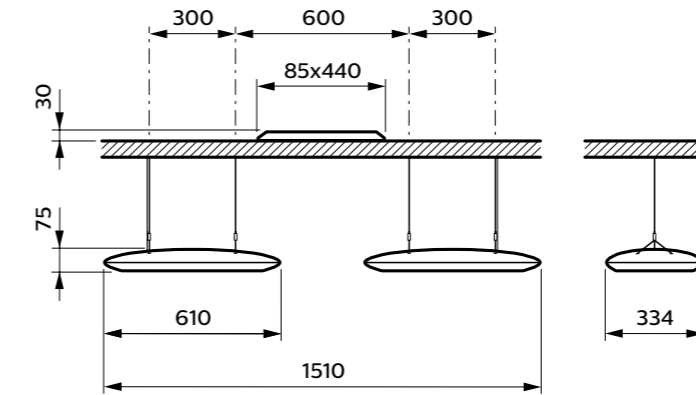

Photometric data

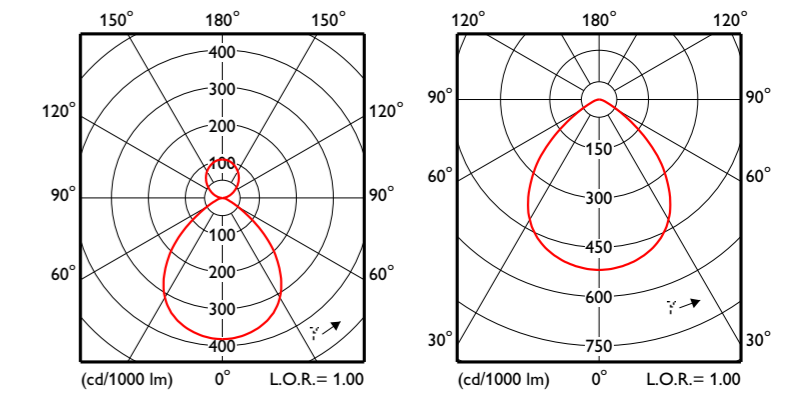



LuxSpace

LuxSpace provides the perfect combination of efficiency, light comfort and design, without compromising on lighting performance (color rendering and color uniformity). It offers a wide choice of options for creating the desired ambience.



High efficiency, visual comfort and a stylish design

Highly efficient

The highly energy-efficient LuxSpace makes it possible to achieve extremely low power consumption without sacrificing light quality. This results in upto 50% energy savings compared to traditional CFL downlights.

Latest technology

LuxSpace features the latest LED technology and delivers reliable light output, stable color performance and high color rendering (Ra = 80).

Fit and forget

All LuxSpace models offer a compact look and feel, and a perfect fit with easy installation, with a long lifetime of 50,000 hours, which means an end to the hassle of relamping.

Variants >



High glass optic



Facetted optic



Matt optic



White optic



Recommended applications

Open office areas

Selling floors

Reception and corridors

Product features:

- Highly efficient, efficacy >90 lm/W
- Compact look and feel
- Premium material and finish





LuxSpace

Technical specifications

Luminaire

Type	BBS478, BBS488/489, BBS498/499, BBS496	Dimmable/Non Dimmable	DALI
Beam angle	WB	Classifications (IP/IK)	IP20 (Option of IP54)
Installation/mounting type	Recessed	Optical System	Steel and polycarbonate
Color Temperature Tc (K)	3000 / 4000	Cover (Glass/ PC)	Option of various attachments
Color Rendering Index (Ra)	>80	Life in hours (@ L70)	Upto 50,000
Housing (Material And Finish)	Frame: steel Components: polycarbonate Reflector: anodized aluminum, semi-high-gloss	Electrical Class	Class II
System Wattage (W)	8 / 13 / 28 / 40.5	Driver	
System Voltage (V)	220-240 / 50-60 Hz	Driver Type	Integrated
System Lumen Package (lumens)	600 / 1000 / 1500 / 2000 / 3000	Operating Voltage (V)	220-240
System Efficacy (lm/W)	Upto 100	Surge Protection	NA

Dimensional drawing

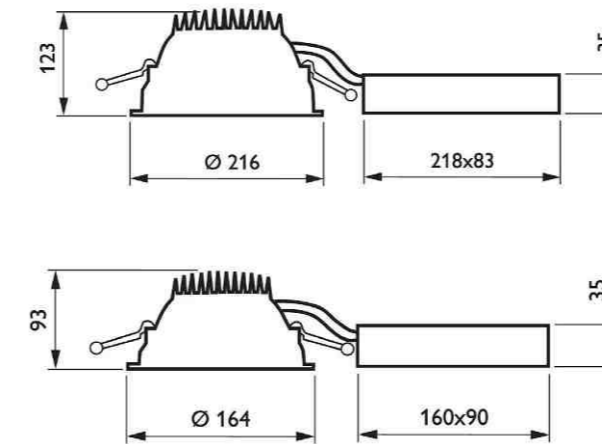

Photometric data

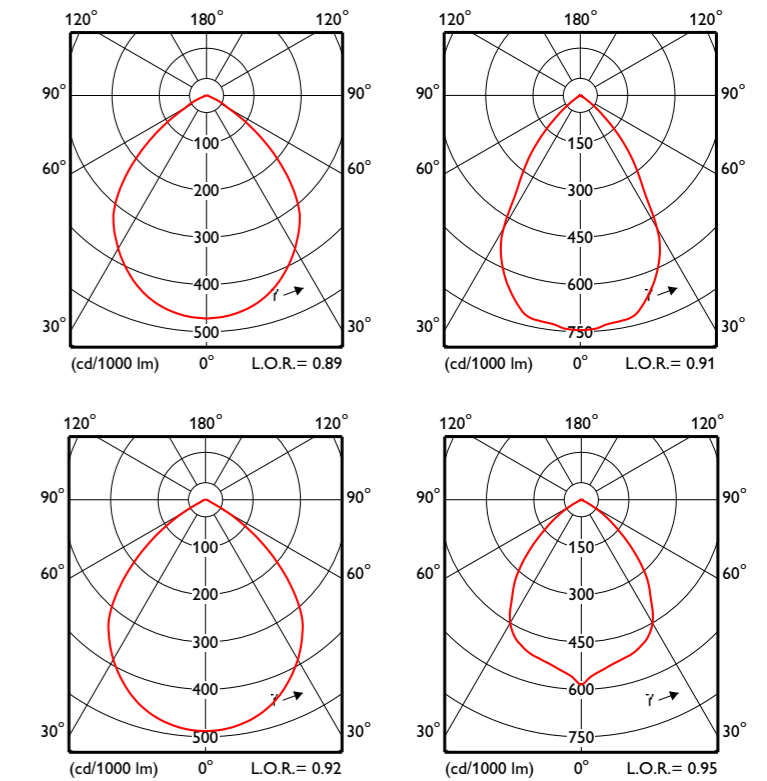



Rotaris

The defining visual characteristic of the Rotaris product range, which is based on the innovative TL5 Circular lamp, is its concentric circles. The semi-high-gloss aluminum centerpiece is surrounded by an opal or clear lamp cover, the inside of which has a prismatic structure, again in concentric circles.



Recommended applications

Open office areas

Selling floors

Meeting rooms

The perfect form

Innovative design

Concentric circles and a semi-high-gloss aluminum centerpiece define visual characteristics.

Smooth visual integration

With TBS740, the outer rim of the luminaire, forms one piece with the optic, interfaces with the ceiling, ensuring its smooth visual integration in a space.

Mounting options and glare control

Controlled in all viewing directions by Omni-directional Luminance Control technology, a complete range of surface-mounted, recessed and suspended luminaires is available.

Variants >



Product features:

- Semi-high-gloss aluminum centerpiece
- High-reflectance optic
- Omni-directional Luminance Control (OLC)





Rotaris

Technical specifications

Luminaire

Type	TBS740	Dimmable/Non Dimmable	Dimmable
Beam angle	NA	Classifications (IP/IK)	IP20
Installation/mounting type	Suspended, recessed	Optical System	NA
Color Temperature Tc (K)	Depending on lamp type	Cover (Glass/ PC)	Opal cover (O) Prismatic cover (P) Opal cover with (diffusing) filter plate (O-FP) Prismatic cover with (diffusing) filter plate (P-FP)
Color Rendering Index (Ra)	Depending on lamp type	Life in hours (@ L70)	Depending on lamp used
Housing (Material And Finish)	Frame: steel Components: polycarbonate Reflector: anodized aluminum, semi-high-gloss	Electrical Class	Class I
System Wattage (W)	60	Light source	1 x MASTER TL5 Circular / 2GX13 / 60W
System Voltage (V)	220-240 / 50-60 Hz	Driver	
System Lumen Package (lumens)	Depending on lamp used	Driver Type	Electronic
System Efficacy (lm/W)	Depending on lamp used	Operating Voltage (V)	220-240
		Surge Protection	NA

Dimensional drawing

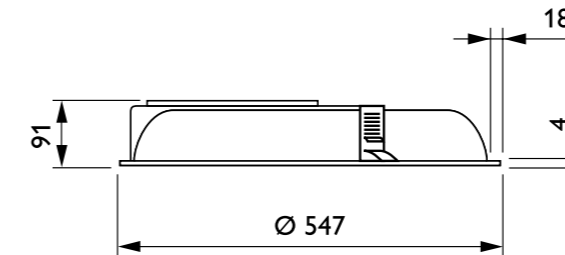

Photometric data

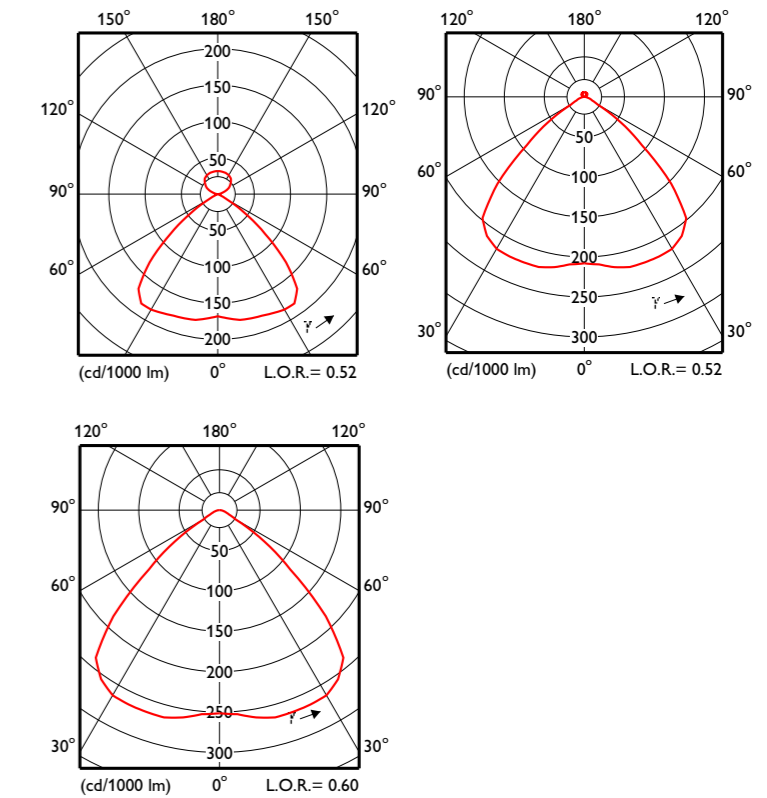



StyliD

Retailers and hospitality operators are increasingly having to contend with rising energy prices. They need to retain the quality of light used which is flexibility in architectural integration and provides the right light effects to catch the customer's eye. StyliD Compact is the ideal energy efficient solution for today's demanding retail applications.



Recommended applications

- Fashion and food stores
- Lobbies and reception areas
- Meeting rooms



Energy efficient solution

Highly energy efficient

Delivering high-quality light with ideal energy-efficient solution for today's demanding retail applications. Compared to CDM-Elite it is up to 45% more efficient.

Wide range of options

The fixture comes with fixed / adjustable solutions with varied lumen output options.

Retail lighting applications

With its narrow beam option and good quality of light, it provides full coverage of retail lighting applications.



Variants >



Mini, track and surface mounted



Performance, track and surface mounted



Performance, FreshFood Rose

Product features:

- High efficacy - 80 lm/W
- High light color consistency
- Versatile applications





StyliD

Technical specifications

Luminaire

Type	ST540T (3C-track version)	Dimmable/Non Dimmable	Dimmable
Beam angle	NB (8°), MB (25°), WB (35°)	Classifications (IP/IK)	IP20
Installation/mounting type	On 3-circuit track (3C) Direct on ceiling; baseplate with connection point (BA)	Optical System	NA
		Cover (Glass/ PC)	Glass
Color Temperature Tc (K)	3000 / 4000	Life in hours (@ L70)	Upto 50000
Color Rendering Index (Ra)	80 (90 on request)	Electrical Class	Class I
Housing (Material And Finish)	Die-cast aluminum		
System Wattage (W)	23 / 36	Driver	
System Voltage (V)	220-240 / 50-60 Hz	Driver Type	Integrated
System Lumen Package (lumens)	1700 / 2700	Operating Voltage (V)	220-240
System Efficacy (lm/W)	Upto 75	Surge Protection	As per relevant IS standard only

Dimensional drawing

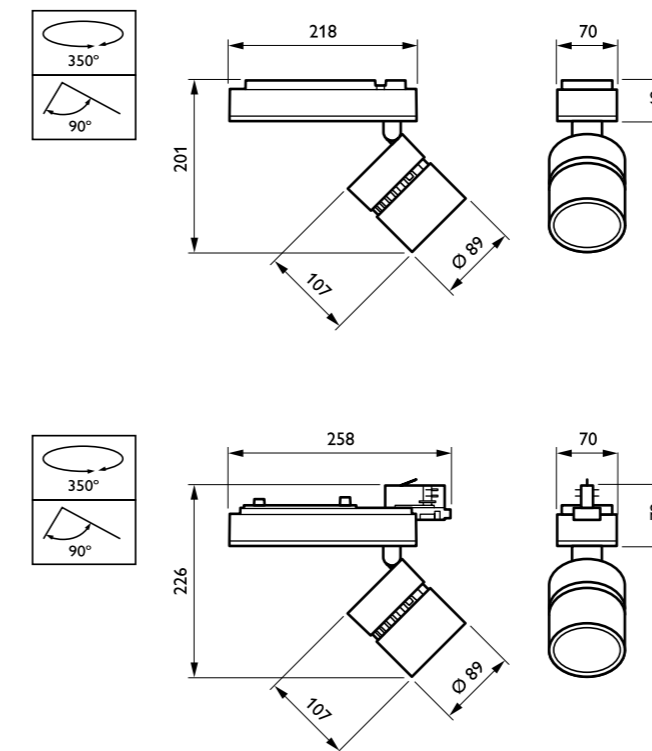

Photometric data

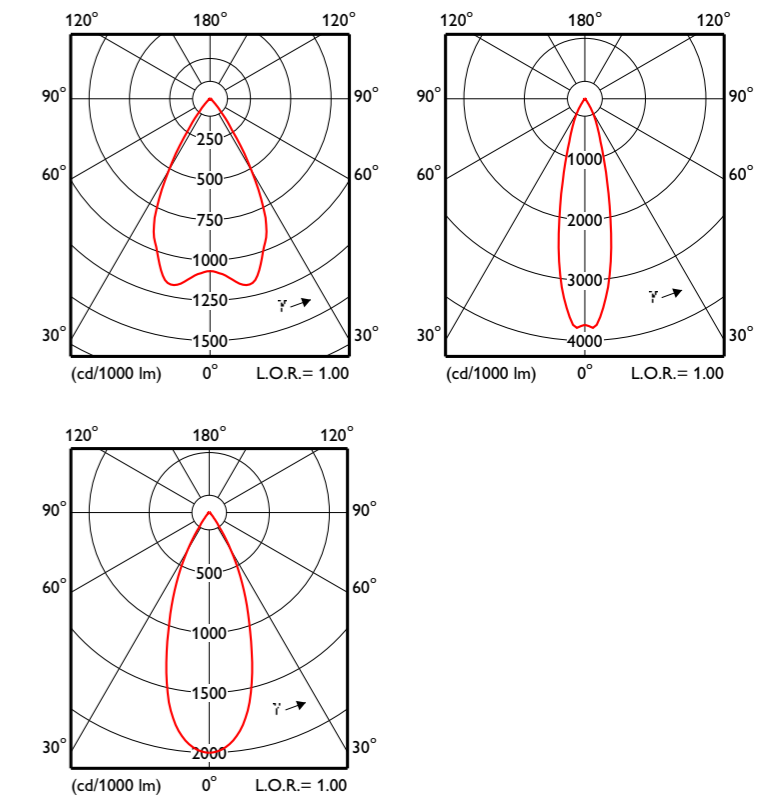

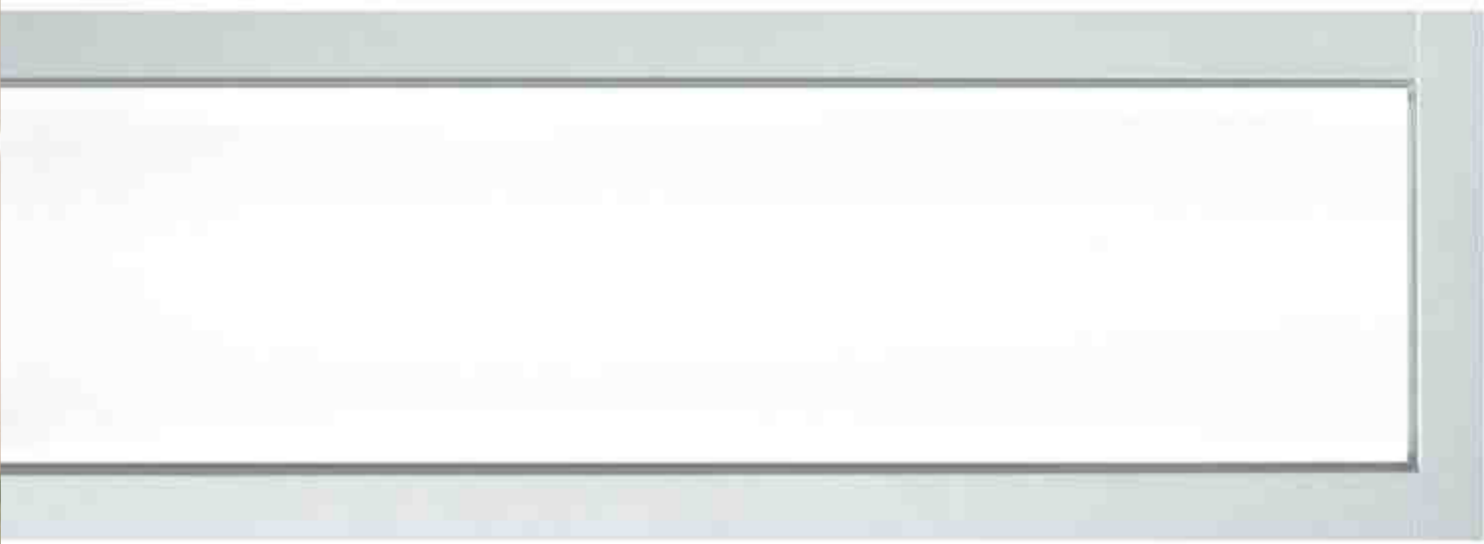

TruGroove

TruGroove is an epitome of simple sophistication that delivers unrivaled performance with innovative design, making a definitive statement in any architectural space. It provides an endless opportunities for geometric patterns in walls and ceilings.



Transforming light into an element of design

Exceptional performance

TruGroove offers the best possible combination of lighting control and brightness to create a balanced luminous environment with smooth and even gradients of light throughout the space.

Endless design freedom

TruGroove luminaires are available in multiple design options to deliver clean, understated style in any architectural environment.

Easy of installation

TruGroove's unique cable design makes installation simple - a feature that saves time and money.

Variants >

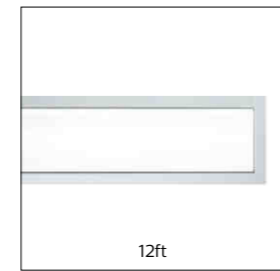
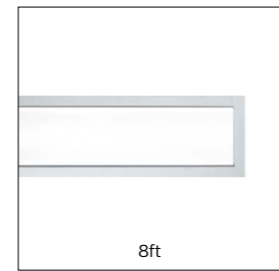
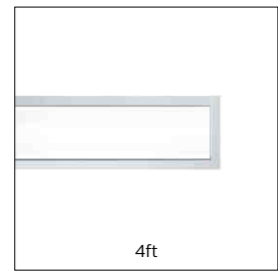

Recommended applications

Open offices

Transition areas

Reception and breakout areas

Product features:

- MesoOptics w/bi-convex lens & Miro-Silver® reflectors
- Multiple design options
- High quality light output and efficacy



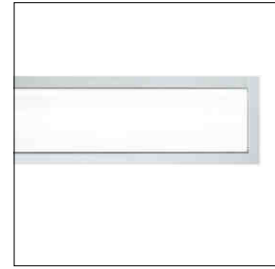

TruGroove

Technical specifications

Luminaire

Type	TruGroove	Dimmable/Non Dimmable	Dimmable
Beam angle	Symmetric	Classifications (IP/IK)	IP20
Installation/mounting type	Recessed	Optical System	Depending on variants
Color Temperature Tc (K)	3000 / 3500 / 4000	Cover (Glass/ PC)	Poly carbonate
Color Rendering Index (Ra)	>80	Life in hours (@ L70)	Upto 50,000
Housing (Material And Finish)	Extruded aluminum trim and die-cast endplates	Electrical Class	Class II
System Wattage (W)	20 / 28 / 42	Driver	
System Voltage (V)	220-240 / 50-60 Hz	Driver Type	Electronic
System Lumen Package (lumens)	1500 / 2200 / 3000	Operating Voltage (V)	220-240
System Efficacy (lm/W)	Upto 82	Surge Protection	NA

Dimensional drawing

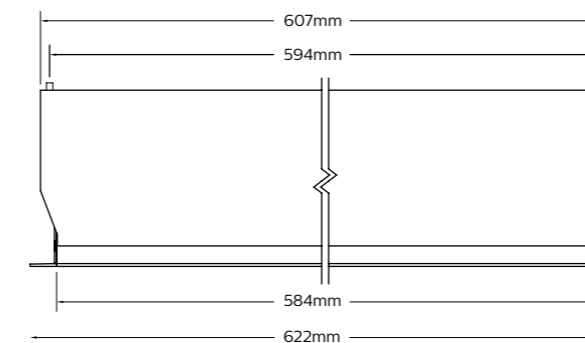

Photometric data

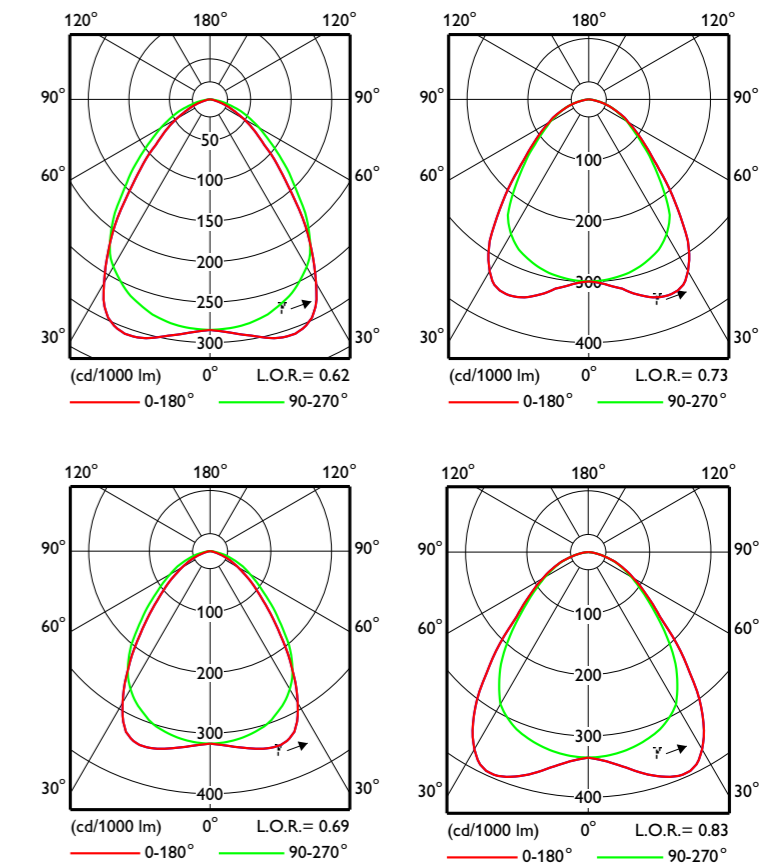



Outdoor lighting

Page No.	Product	Mounting type
136	AmphiLux	Surface
142	Arena Vision	Wall, Floor
148	City Spirit	Pole
154	Decoflood	Recessed, Wall, Floor
160	Decoscene	Floor
166	Mini Stealth	Wall
172	Luma	Pole
178	Jargeau	Pole, Suspended



AmphiLux

Designed and manufactured in Italy, the AmphiLux range of products have been created for outdoor architectural lighting applications. Apart from its beautiful design, the AmphiLux range is packed with useful features to make it suitable for many accent and low-intensity floodlight applications.



Light up your outdoor social areas

Stylish design and quality finish

The beautiful Italian design and high-quality chrome finish makes AmphiLux a stylish choice for outdoor accent lighting and flood lighting.

Quality light with tone options

There is a choice of three tones of high-quality white light: 2700 and 4000 K with CRI>80 and 6000 K with CRI >70 with dynamic color and dynamic white options

Dynamic color spots equipped with RGBW

LEDs that enable true white, pastel or saturated colors to be produced by the same spot. The dynamic white spots vary in color temperature from 2700 to 6000 K.

Variants >

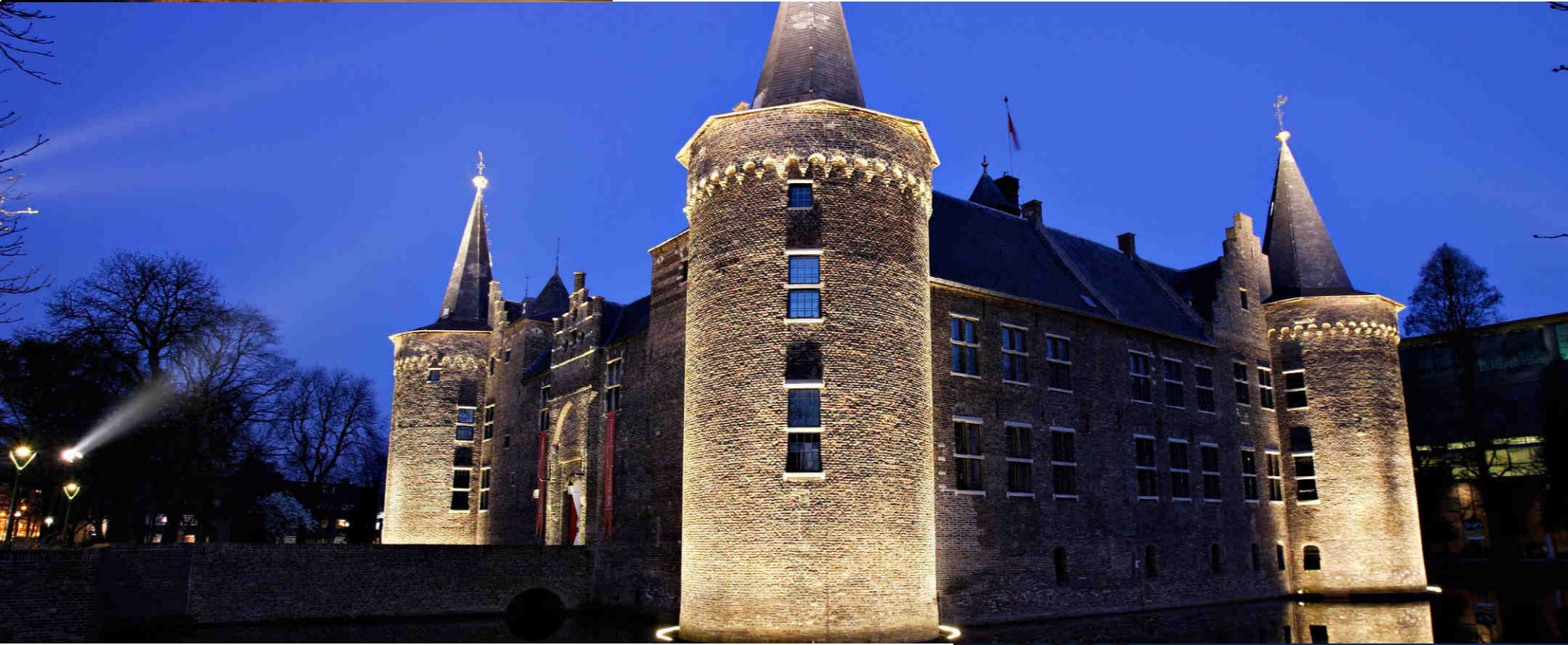

- Product features:**
- Sleek, attractive design
 - Highly efficient, low-power LED spots
 - IP68-rated for underwater use



- Recommended applications**
- Architectural lighting
 - Accent lighting
 - Flood lighting



AmphiLux

Technical specifications

Luminaire

Type	BVD400 Micro (1 x LED, Mono color version) BVD410 Mini (4 x LED, Mono and Dynamic color version) BVD420 Compact (12 x LED, Mono and Dynamic color version)	Dimmable/Non Dimmable	Dimmable
Beam angle	Micro versions: 10°, 20° and 35° Mini and Compact versions: 10° and 40°	Classifications (IP/IK)	IP68
Installation/mounting type	Screwed on surface	Optical System	Hardened glass
Color Temperature Tc (K)	2700, 4000 and 6000	Cover (Glass/ PC)	Glass
Color Rendering Index (Ra)	70 / 80	Life in hours (@ L70)	> 147,000 at 35°C
Housing (Material And Finish)	Housing: chromed brass Optical cover: hardened glass	Electrical Class	Class I
System Wattage (W)	Micro versions: 1.5W Mini version (Mono color): 5W Mini version (Dynamic color): 4W Compact version (Mono color): 15W Compact version (Dynamic color): 12W	Driver	
System Voltage (V)	12 V DC	Driver Type	External
System Lumen Package (lumens)	Micro versions: +/- 60 lm Mini version: +/- 240 lm Compact version: +/- 720 lm	Operating Voltage (V)	220-240
System Efficacy (lm/W)	Upto 75	Surge Protection	As per relevant IEC standard only

Dimensional drawing

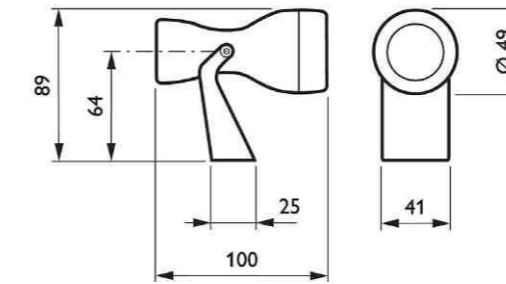

AmphiLux BVD400 surface-mounted



Arena Vision

The ArenaVision MVF404 floodlight – designed for outdoor sports stadiums – dramatically increases the theatrical and emotional impact of sports for TV audiences and spectators, while allowing the players to perform under optimal visual conditions.

Recommended applications

Outdoor sports lighting

Architectural flood lighting

Indoor sports halls

Synergy of lamp, optics and gear design

High optical efficiency

Innovative floodlight with Philips' compact single-ended lamp; dedicated optics ensure maximum optical efficiency and enable accurate light distribution.

Excellent color rendering

Quartz metal halide lamp meets the most demanding lighting and TV broadcast requirements with excellent color rendering.

Flicker free versions

The flicker-free version completely eliminates flicker effect, thereby providing perfect images filmed with super slow motion cameras.



MVF 403C



Product features:

- Housing dust proof and waterproof to IP65; no internal cleaning required
- Built-in reflector reduces spill light and glare
- Wire mesh to prevent large pieces of glass falling out





Arena Vision

Technical specifications

Luminaire

Type	MVF403	Dimmable/Non Dimmable	Non-dimmable
Beam angle	Narrow beam, Medium beam, Wide beam	Classifications (IP/IK)	IP65
Installation/mounting type	On mast head frame, ceiling, wall and floor mounting	Optical System	Front-glass for downlighting (DOWN) and uplighting versions (UP)
Color Temperature Tc (K)	4000/5600	Cover (Glass/ PC)	Front glass: extra white, tempered, 4mm thick
Color Rendering Index (Ra)	90	Life in hours (@ L70)	Depending on lamp type
Housing (Material And Finish)	High-pressure die-cast aluminum	Electrical Class	Class I
System Wattage (W)	2200	Light source	HID 1 x MASTER MHN-SA HO / XW / 2000 W 1 x MASTER MHN-LA / XWH / 1000 W
System Voltage (V)	220-240 / 50-60 Hz	Driver	
System Lumen Package (lumens)	Depending on lamp type	Driver Type	External
System Efficacy (lm/W)	Depending on lamp type	Operating Voltage (V)	220-240
		Surge Protection	As per relevant IES standard

Dimensional drawing

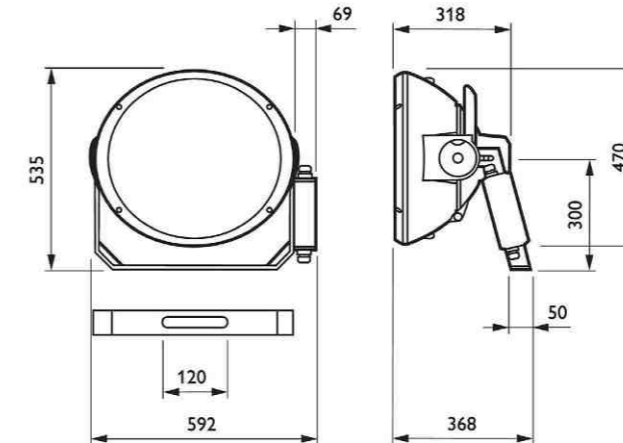

Photometric data

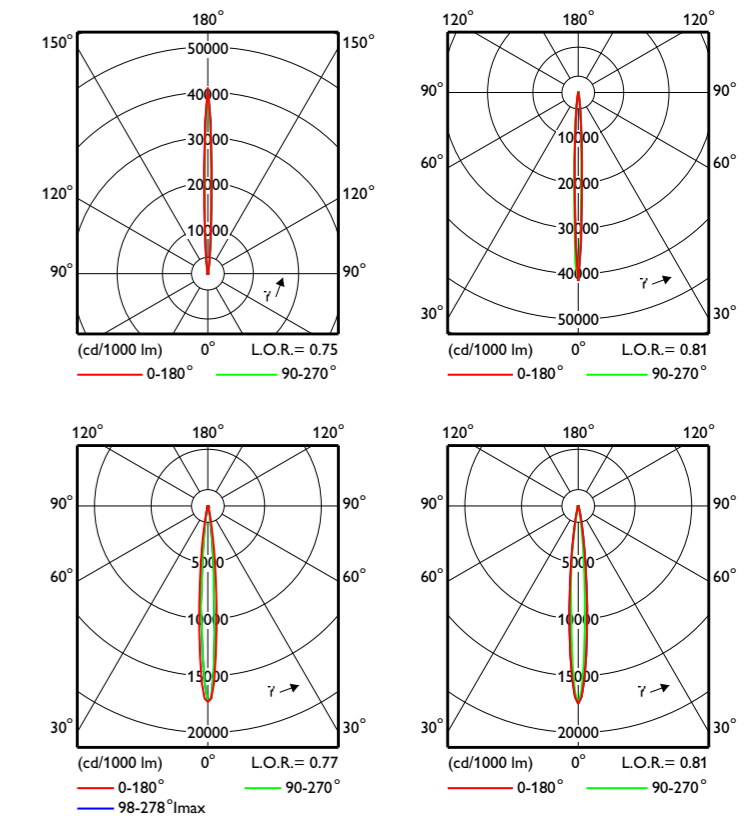



City Spirit

CitySpirit Street is part of the CitySpirit gen2 range, a hybrid range designed to provide excellent, environmentally friendly lighting without compromising on architectural appearance.



Recommended applications

- City centers and squares
- Residential areas
- Promenades

Eco friendly and stylish design

Multiple lighting options

The range consists of indirect lighting solutions, such as the Cone, Torch, Modern Lantern, Classic Lantern and a direct lighting solution, namely CitySpirit Street and CitySpirit Street LED.

One to one replacement

Enables significant energy savings through one to one replacement of HID installations without any compromise on lighting quality or safety.

Highest operational efficiency

Together with its constant light output and dimming functionality, it ensures the highest operational efficiency.



Street gen2 Color LED



Street CDS 480C

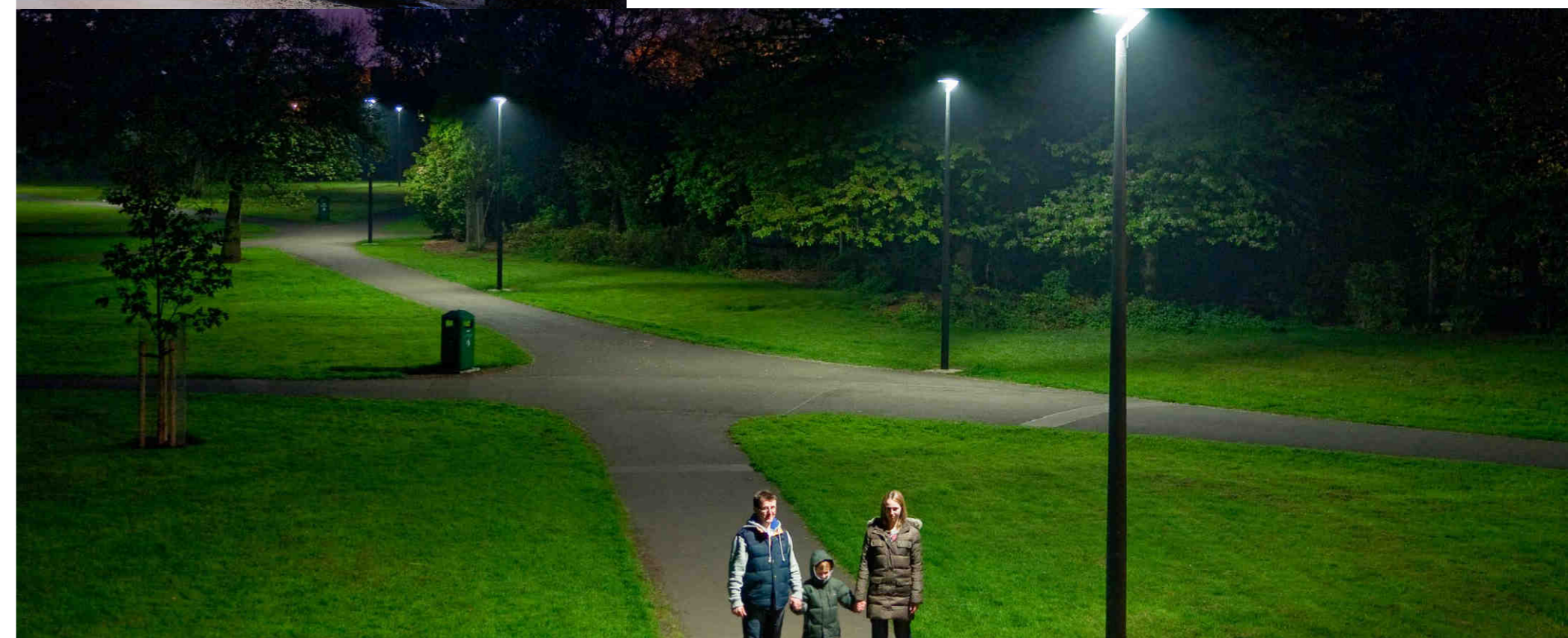

Product features:

- Choice of conventional or LED light sources
- Variety of optics addressing maximum spacing and visual comfort
- LED version available with a transparent ring that can be colored in blue or white

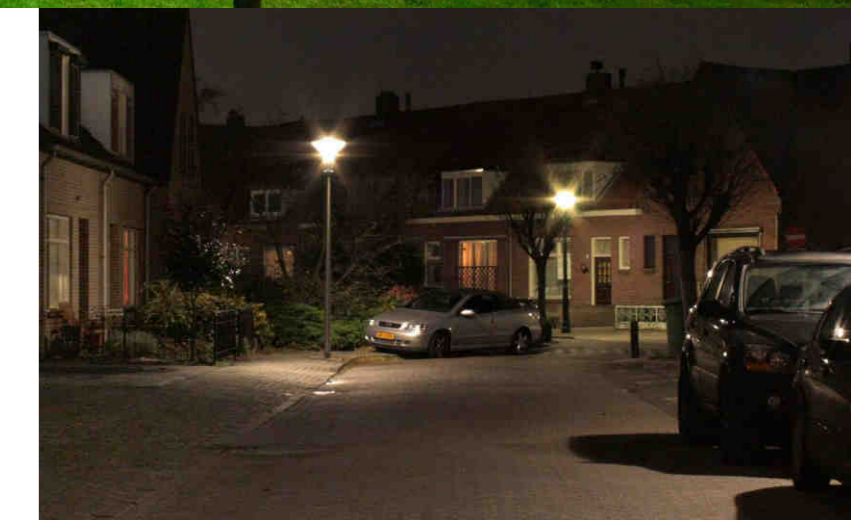



City Spirit

Technical specifications

Luminaire

Type	BDS480	Dimmable/Non Dimmable	Dimmable
Beam angle	Wide beam	Classifications (IP/IK)	IP65
Installation/mounting type	Pole mounted	Optical System	Acrylate
Color Temperature Tc (K)	4000	Cover (Glass/ PC)	Glass
Color Rendering Index –Ra	70	Life in hours (@ L70)	>50,000
Housing (Material And Finish)	Aluminum	Electrical Class	Class I
System Wattage (W)	40 - 140	Driver	
System Voltage (V)	220-240 / 50-60 Hz	Driver Type	Integrated
System Lumen Package (lumens)	4000 - 14000	Operating Voltage (V)	220-240
System Efficacy (lm/W)	100	Surge Protection	As per relevant IEC standard only

Also available with conventional lamp

Dimensional drawing

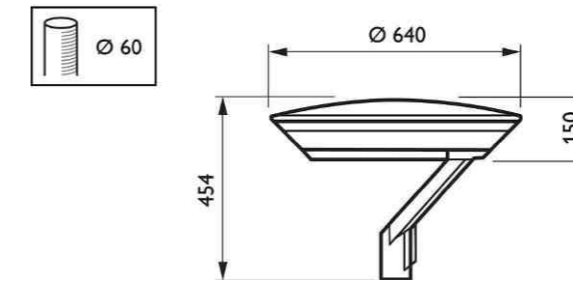

Photometric data

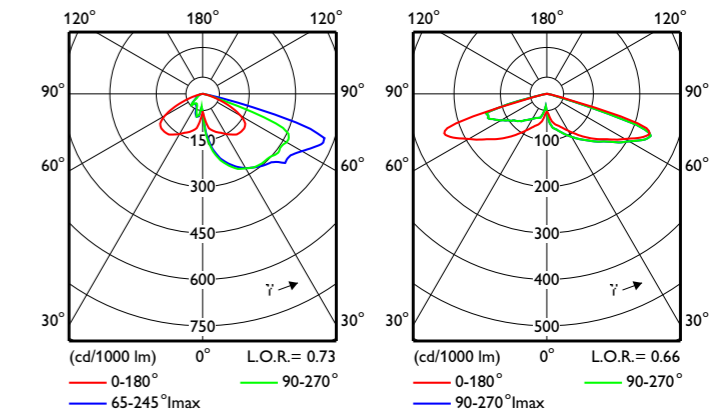



Decoflood

Available in both LED and conventional versions, Decoflood and MiniDecoflood floodlights are ideal for illuminating a wide variety of structures with reflectors for accent lighting, façade lighting, area lighting and architectural street lighting.



Recommended applications

Accent lighting

Façade and area lighting

Architectural street lighting

The complete lighting solution

Zoom Focus

Zoom Focus has been specially developed for Decoflood DVP626 and 627. A simple screw on the outside of the floodlight which allows you to change the beam while the floodlight is operational.

Eco-friendly design

Decoflood is an unobtrusive range of floodlights, combining simple shapes with pure design. It integrates perfectly in urban environments where the daytime appearance of buildings is as important as lighting effects at night.

Variants >



LED mini



LED BVP626, 636-646



DCP623 mini



DCP624 mini



DVP626



DVP627



DVP628



DVP637



Product features:

- High-quality anodized aluminium reflectors
- Protractor scale for easy aiming.
- Fast access to lamp and terminal blocks through the front with snap-action clip





Decoflood

Technical specifications

Luminaire

Type	DVP636	Dimmable/Non Dimmable	Dimmable
Beam angle	Narrow beam, Medium beam, Wide beam, Asymmetrical beam A45, A60	Classifications (IP/IK)	IP65
Installation/mounting type	Ceiling/Wall/Floor	Optical System	CosmoPolis optic OC
Color Temperature Tc (K)	3000/4000	Cover (Glass/ PC)	Front glass: extra white, tempered, 4mm thick
Color Rendering Index (Ra)	80	Life in hours (@ L70)	Depending on lamp type
Housing (Material And Finish)	Die-cast aluminum	Electrical Class	Class I
System Wattage (W)	70, 150	Light source	HID
System Voltage (V)	220-240 / 50-60 Hz	Driver	
System Lumen Package (lumens)	Depending on lamp type	Driver Type	Integrated
System Efficacy (lm/W)	Depending on lamp type	Operating Voltage (V)	220-240
		Surge Protection	As per relevant IS standard only

Dimensional drawing

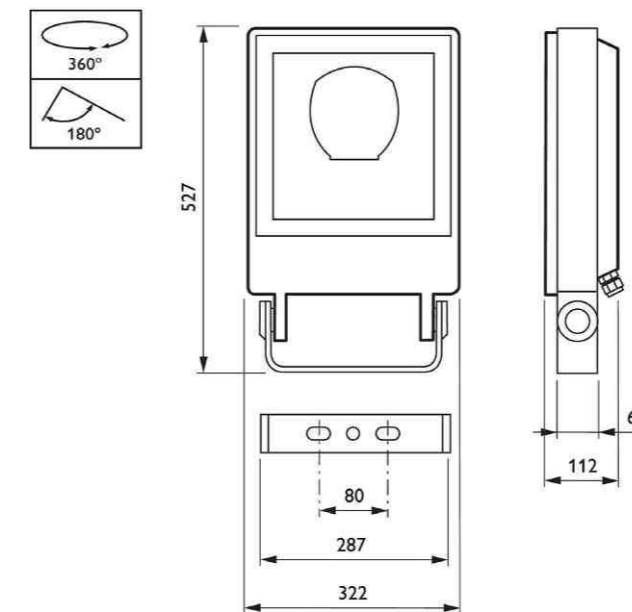

Photometric data

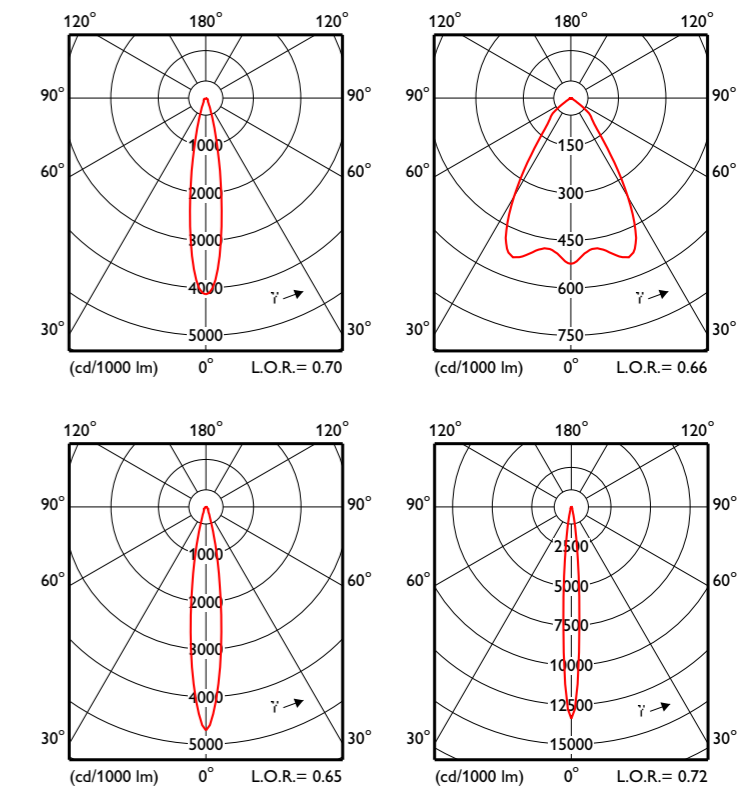



DecoScene

DecoScene is a ground-recessed uplighter for enhancing, highlighting or even revealing the architecture of the city at night. An unobtrusive presence by day, DecoScene offers a wide choice of light sources, beams, adjustment possibilities and accessories to deliver the optimum upward lighting effect after dark.



Recommended applications

Architectural flood lighting

Residential areas

Parks and gardens

Bringing the night scene to life

Unobtrusive presence

Uplighter that brings the night scene to life by enhancing or highlighting the city architecture at night, while remaining unobtrusive during the day.

Upward light effect

Wide choice of light sources, beams, adjustment possibilities and accessories to deliver the optimum upward lighting effect after dark.

Enhanced guidance

Illuminates monuments, highlights striking pieces of contemporary architecture and marks out a luminous path through a public park or garden.

Variants >



DBP521



DBP522



DBP523



LED BBP621



LED BBP623

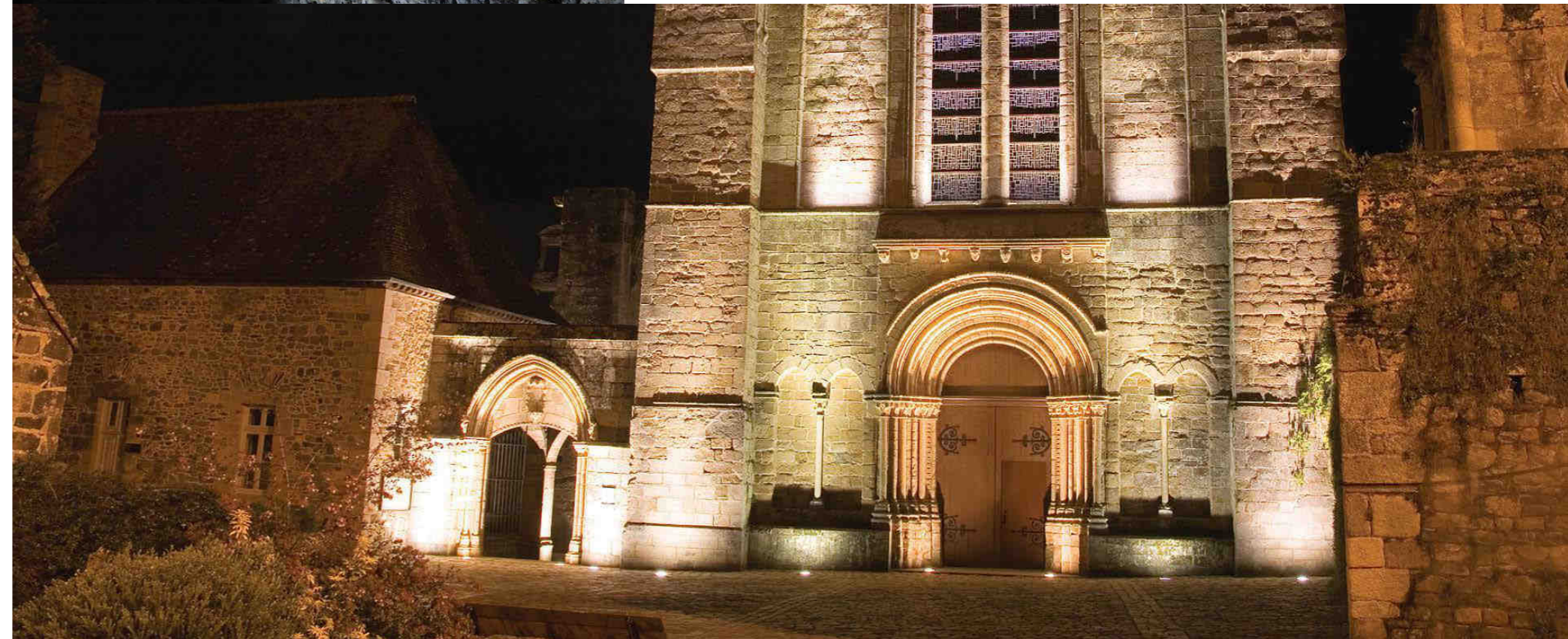

Product features:

- Choice of conventional and LED versions
- Wide choice of lamps, beams, adjustment possibilities and accessories
- Complies with CEI 60598-2-13 norm





DecoScene

Technical specifications

Luminaire

Type	DBP522	Dimmable/Non Dimmable	Non-dimmable
Beam angle	Narrow beam, Medium beam, Wide beam, Asymmetrical beam	Classifications (IP/IK)	IP65
Installation/mounting type	Floor	Optical System	Anodized aluminum
Color Temperature Tc (K)	3000 / 4000	Cover (Glass/ PC)	Front glass:extra white, tempered, 4mm thick
Color Rendering Index (Ra)	80	Life in hours (@ L70)	Depending on lamp type
Housing (Material And Finish)	Die-cast aluminum	Electrical Class	Class I
System Wattage (W)	35 / 70	Light source	MASTERColour CDM-T / G12 /35, 70W MASTERColour CDM-TD / RX7s /70W
System Voltage (V)	220-240 / 50-60 Hz		
System Lumen Package (lumens)	Depending on lamp type	Driver	
System Efficacy (lm/W)	Depending on lamp type	Driver Type	Integrated
		Operating Voltage (V)	220-240
		Surge Protection	As per relevant IS standard only

Dimensional drawing

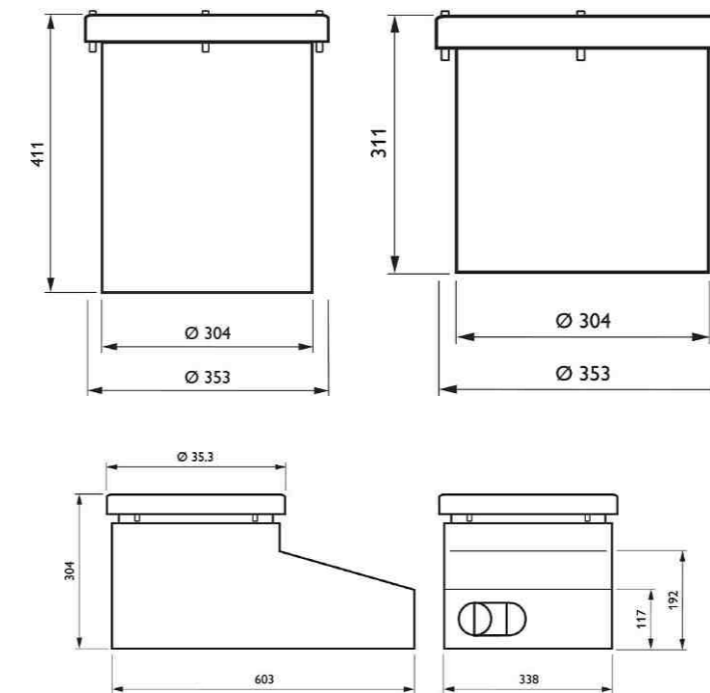

Photometric data

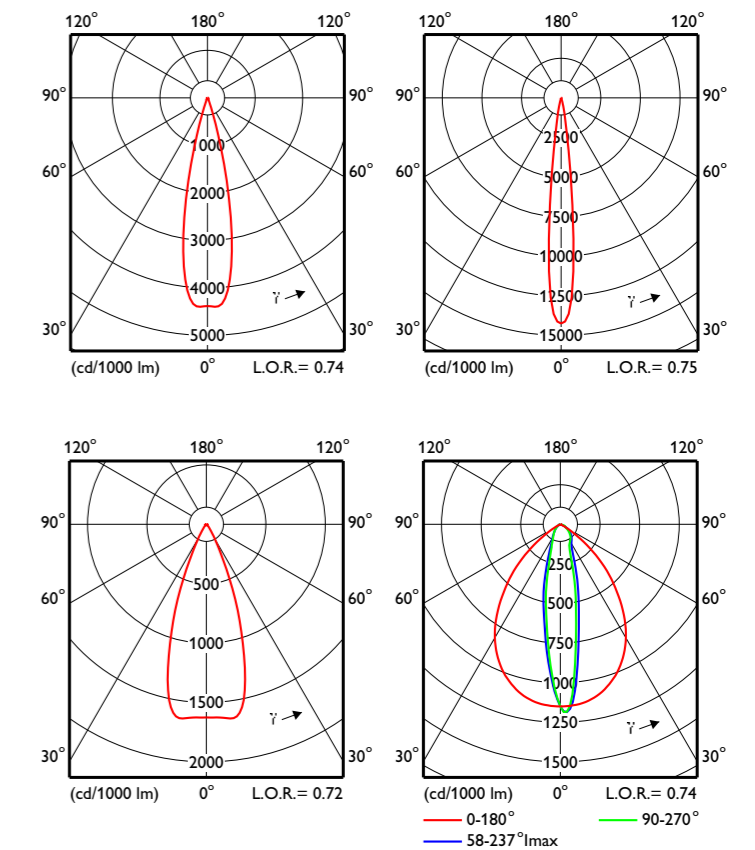



Mini 300 Stealth

Mini 300 Stealth is a range of extremely efficient luminaires – with a choice of HID or LED light sources – that can be used to illuminate large areas with direct and/or indirect light. It suitable for pole mounting, wall mounting or floodlighting. Within the product family there is also a dedicated under-canopy version, e.g. for petrol-station applications.



Recommended applications

Urban and public areas

Shopping malls

Transportation hubs

A luminaire with visual power

High visual power

A range of extremely efficient luminaires that can be used to illuminate large areas with direct and/or indirect light.

High light output

It gives optimal lighting results with a good balance of horizontal and vertical light levels and good color rendering.

Versatile

Supplied with asymmetrical, wide, medium or narrow-beam reflector. Also available with POT road lighting optic for perimeter, parking and open area lighting.

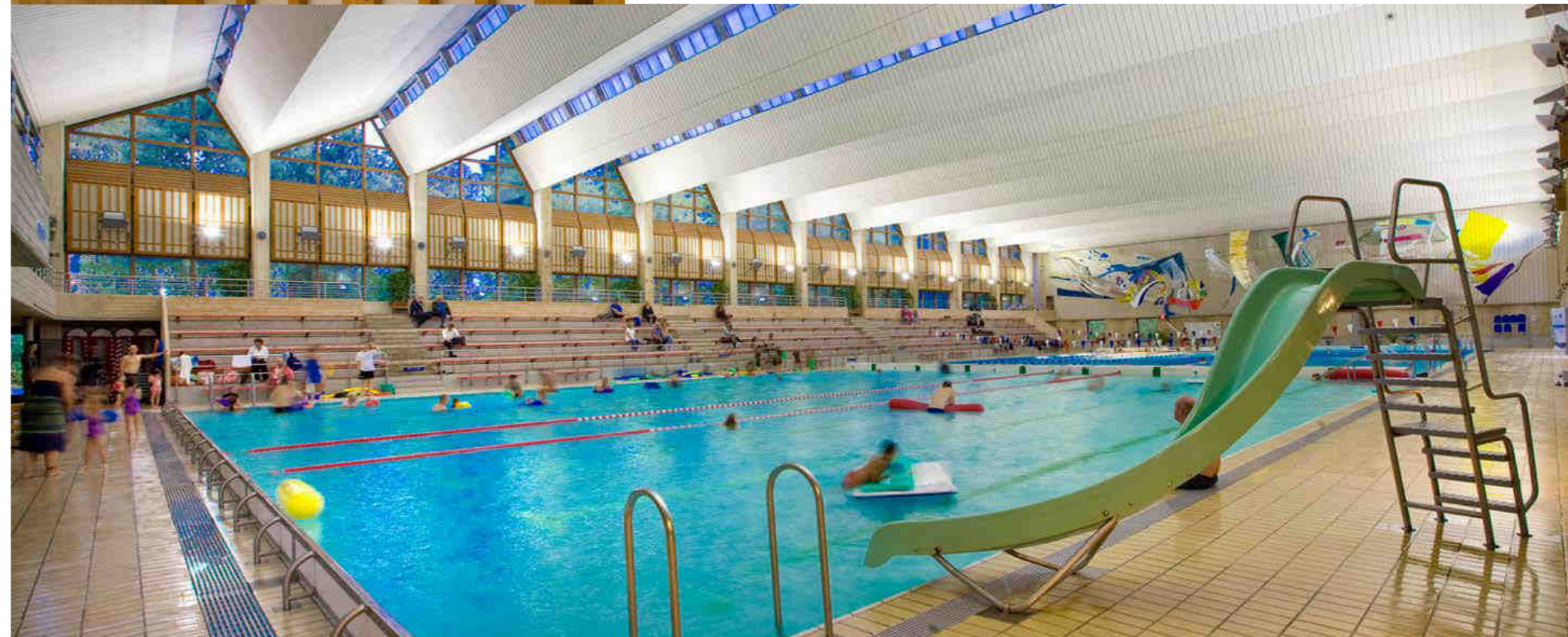

Product features:

- Patented louver system
- Good balance of horizontal and vertical light levels
- Choice of HID or LED light sources





Mini Stealth

Technical specifications

Luminaire

Type	DWP333	Dimmable/Non Dimmable	Non-dimmable
Beam angle	Asymmetric	Classifications (IP/IK)	IP65
Installation/mounting type	Wall mounting	Optical System	NA
Color Temperature Tc (K)	3000/4000	Cover (Glass/ PC)	Glass
Color Rendering Index (Ra)	80	Life in hours (@ L70)	Depending on lamp type
Housing (Material And Finish)	High pressure die-cast aluminum	Electrical Class	Class 1
System Wattage (W)	70/150	Light source	HID: 1 x MASTER CosmoWhite CPO-TW / PGZ12 / 45, 60, 90 W 1 x MASTERColour CDM-T / G12 / 70, 150, 250 W 1 x MASTERColour CDM-TD / RX7s / 70, 150 W 1 x MASTER CDM-TMW 210 W
System Voltage (V)	220-240 / 50-60 Hz		
System Lumen Package (lumens)	Depending on lamp type		
System Efficacy (lm/W)	Depending on lamp type		

Driver

Driver Type	Integrated
Operating Voltage (V)	220-240
Surge Protection	As per relevant IEC standard only

Dimensional drawing

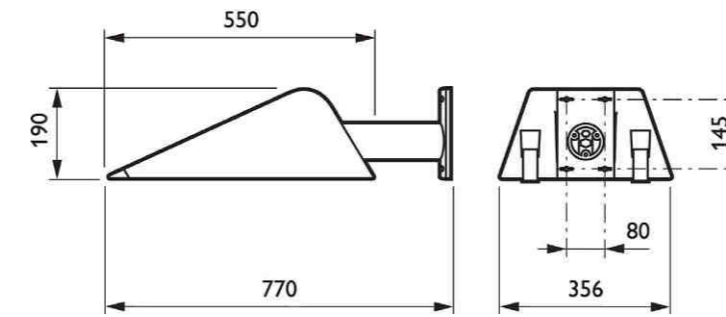

Photometric data

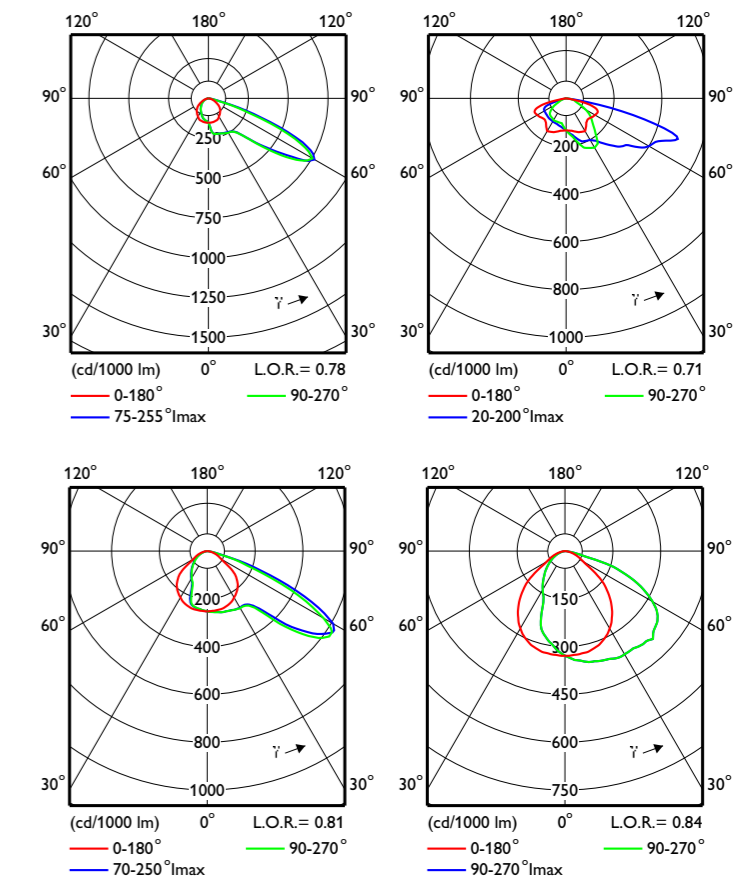



Luma

Luma is a REVOLED™ road lighting luminaire with a clear identity, offering perfectly cooled, fit and forget solutions for all streets and roads. With the L-Tune tool the lumen package, life time and energy profile can be tuned to a preferred solution in terms of energy and costs. The real flat design prevents upward light and the OPTIFLUX™ lens optics meet current lighting standards in an effective way.



Recommended applications

Urban and public areas

Parking areas

Petrol station

Advanced revoled technology

Optical management

Addresses aspects like light output ratio, light distributions and tilt options as well as distribution reliability after incidental individual LED failure.

Thermal management

Concerns aspects like thermal resistance of the LEDs, interdistance of the LEDs in the luminaire and heat dissipation from the LEDs.

Design approach

The design of the luminaire is optimal for use of technical LED characteristics in a dedicated new design concept or by backward engineering where LED engines are installed in existing luminaires.



Variants >



Luma mini
Post-top Ø 76mm



Luma mini
Side-entry Ø 32-60mm
Post-top Ø 60mm



Luma 1
Post-top Ø 76mm



Luma 1
Side-entry Ø 32-60mm
Post-top Ø 60mm



Luma 2
Post-top Ø 76mm



Luma 2
Side-entry Ø 42-60mm
Post-top Ø 60



Luma 3
Post-top Ø 76mm



Luma 3
Side-entry Ø 42-60mm
Post-top Ø 60mm

Product features:

- Choice of lens optics to match international road and street geometries
- Combination of lenses and tilt adjustment options ensure high project flexibility
- Dedicated lumen packages deliver energy savings of over 50%, with a related reduction in CO2 emissions



Luma

Technical specifications

Luminaire

Type	Luma Mini (up to 40 LEDs), Luma 1 (up to 80 LEDs), Luma 2 (up to 120 LEDs), Luma 3 (up to 200 LEDs)	Dimmable/Non Dimmable	Dimmable/Non-dimmable
Beam angle	NA	Classifications (IP/IK)	IP66 / IK09
Installation/mounting type	Post top and Side entry	Optical System	R1 - R10
Color Temperature Tc (K)	3000 / 4000 / 5700	Cover (Glass/ PC)	Flat Glass
Color Rendering Index (Ra)	70	Life in hours (@ L70)	> 50,000
Housing (Material And Finish)	Die-cast aluminum	Electrical Class	Class I
System Wattage (W)	10 to 446 depending on LED configuration and color temperature	Light source	LED
System Voltage (V)	220-240 / 50-60 Hz	Driver	
System Lumen Package (lumens)	850 to 54,400 depending on LED configuration and color temperature	Driver Type	Integrated
System Efficacy (lm/W)	Up to 129	Operating Voltage (V)	220-240
		Surge Protection	As per relevant IES standard only

Dimensional drawing

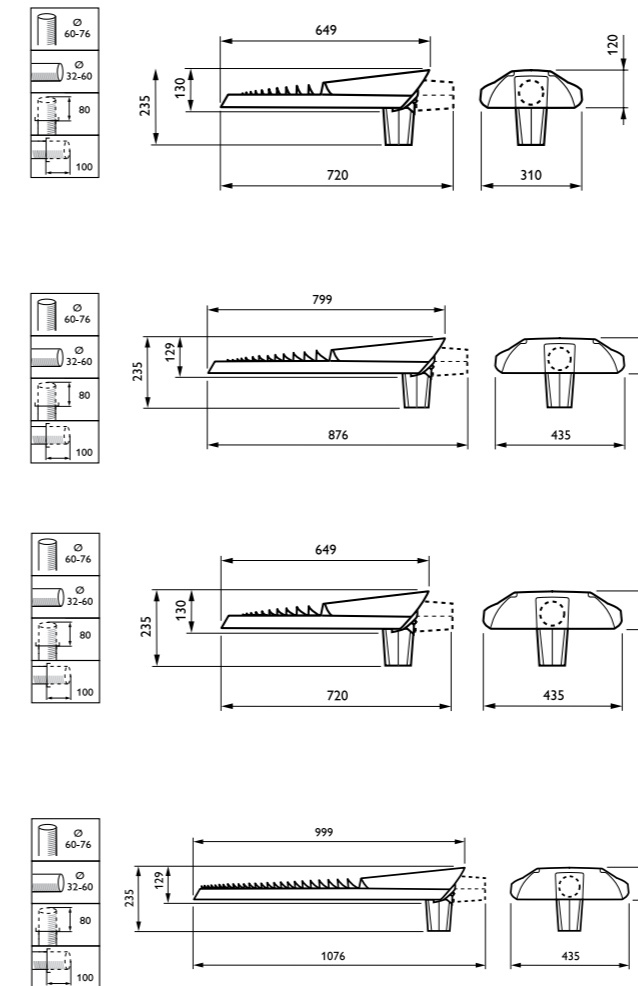

Photometric data

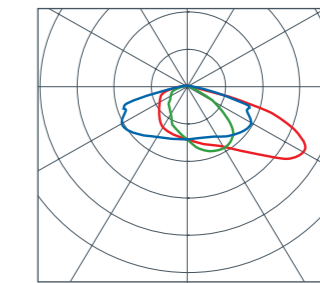



Jargeau

Jargeau 400 combines the symbolic features of the first four-sided street lamps of the 19th century with the technical performance of 21st century luminaires. With a completely updated design, it allows to meet the highest requirements in terms of photometry, IP rating (double ingress protection - DIP), impact resistance and facilitated and safe maintenance (SMT in Class II). Made of cast aluminium, for heights of 4-7 meters, this luminaire is well accepted in our urban landscapes and ideal for lighting city centres, historic areas, old villages, residential environments, streets and alleys, squares and parks.



Recommended applications

Urban and public areas

Parking areas

Petrol station



Advanced Revoled technology

High performance

The flat glass version gives the Jargeau 400 an extra vandal-proof property and optimizes its performance, while considerably reducing light pollution.

Premium aesthetics

The housing of Jargeau 400 is made of two parts in gravity-cast aluminium (upper canopy and lower frame/stirrup) in a polyester powder coating finish in RAL and Futura Akzo Nobel colors.



Product features:

- Advanced design for high performance
- Impact resistance
- Facilitated and safe maintenance





Jargeau

Technical specifications

Luminaire

Type	Jargeau	Dimmable/Non Dimmable	Non dimmable
Beam angle	NA	Classifications (IP/IK)	IP66 / IK10
Installation/mounting type	Top or suspended	Optical System	VRL / iReflec100 / iReflec220
Color Temperature Tc (K)	3000 / 4000	Cover (Glass/ PC)	NA
Color Rendering Index (Ra)	70	Life in hours (@ L70)	Depending on lamp type
Housing (Material And Finish)	Gravity die cast	Electrical Class	Class I, Class II
System Wattage (W)	45-150	Light source	High pressure sodium / ceramic metal halide
System Voltage (V)	220-240 / 50-60 Hz	Driver	
System Lumen Package (lumens)	Depending on lamp type	Driver Type	Integrated
System Efficacy (lm/W)	Depending on lamp type	Operating Voltage (V)	220-240
		Surge Protection	As per relevant IEC standard only

Dimensional drawing

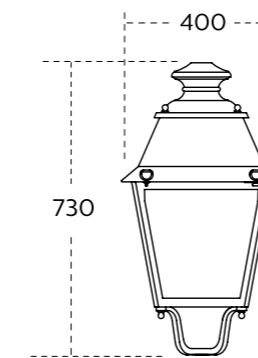

Photometric data

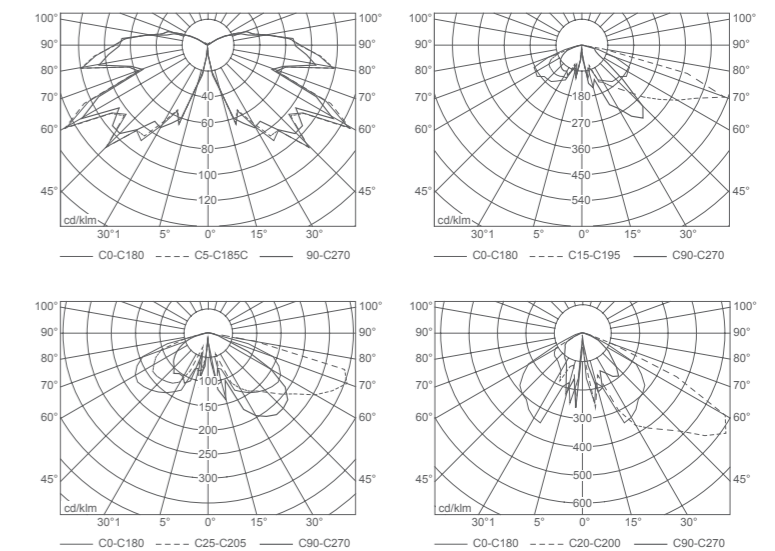



LED lamps

Page No. Product

188	MR16
189	GU10
190	Master LED tube
191	Essential LED tube
192	AR111
193	Master LED PAR
194	Nova Glow
195	MR11
196	Stellarbright
197	Ace Saver



Transforming LED lighting

LED lighting is changing the world and Philips is driving this transformation with a whole new world of light. At Philips, every innovation is driven by the needs of people, to help them feel more comfortable and improve the functionality of their surroundings.

your current luminaires and systems. They are backed by our technological leadership, extensive experience in designing and deploying LED lighting solutions, our market-driven system infrastructure, and the customer care from Philips.

The Philips LED lamps is a line of screw-in and twist-in retrofits that brings all the benefits of LEDs to



MR16

MASTER LED MR16 lamp integrates leading high power LED light source and compact high efficiency driver into a traditional halogen form factor. It is ideal for applications including track lighting, general architectural and landscape lighting.

Product features:

- Upto 90%* energy savings
- Long life - 40000* hours
- Eco friendly - No use of mercury
- High quality light output



GU10

Efficient accent lighting is now possible with GU10 MASTER LED lamp. With no heat, UV or IR in the beam, it outperforms halogen lighting in terms of lighting while saving on energy and maintenance costs.

Product features:

- Upto 88%* energy savings
- Long life - 40000* hours
- Eco friendly - No use of mercury
- High quality light output





Master LEDtube

Philips Master LEDtube integrates LED light source with frosted cover design into a traditional linear fluorescent form providing high efficacy and 60%* energy savings. It is available in 10W, 16W and 20W. It is suitable for factories, supermarkets and offices.

Product features:

- Upto 60%* energy savings
- Long life - 40000* hours
- High efficacy > 100 lm/W
- Eco friendly - No use of mercury



Essential LEDtube

Philips Essential LEDtube integrates LED light source with frosted cover design into traditional linear fluorescent form consuming only 20W and offers energy saving upto 50%.

Product features:

- Upto 50%* energy savings
- Long life - 30000* hours
- Eco friendly - No use of mercury
- Good light output





AR111

Delivering a warm, halogen-like accent beam, MASTER LEDspot LV AR111 is an ideal retrofit solution for spot and general lighting applications in the hospitality and retail industry. It offers various beam angles for a clearly defined beam spread.

Product features:

- Clearly defined beam spread
- Patented intelligent driver
- Long life - 40,000* hours
- Dimmable



Master LED PAR



Philips MASTER LED PAR30 and PAR38 integrates a high power LED light source with excellent thermal management solution in a standard halogen form-factor to replace up to 75W traditional halogen lamp.

Product features:

- 80%* energy savings
- Long life - 45,000* hours
- Eco friendly - No use of mercury
- Good light output

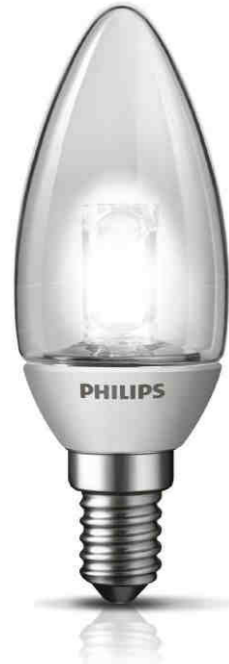

NovaGlow

Philips NovaGlow E14 CANDLE integrates a high power LED light source with a unique lotus lens design for sparkling effect. It can replace up to 20W GLS candle.

Product features:

- Long life - 20,000* hours
- No external driver required
- No mercury, UV and IR
- Dimmable



MR11



Delivering a warm, halogen-like accent beam, MASTER LEDspot LV is an ideal retrofit solution for spot and general lighting applications. It is particularly suited for public areas such as receptions, lobbies, corridors, stairwells and washrooms, where the light is on all the time.

Product features:

- 80%* energy savings
- Clearly defined beam spread
- UV and IR free
- Good light output



Stellarbright

The Stellarbright range of LED Bulbs are engineered to deliver 90% more brightness than equivalent wattage CFL bulb. Stellar Bright LED Bulb's are available in different wattages giving far higher light output than other LEDs/ CFLs. These retrofit bulbs can be easy replacements for older CFL and GLS bulbs. Change to an energy efficient bright future with Stellar bright.

Product features:

- Upto 40% energy saving over 23W CFL*
- Long life upto 15 years*
- Light output of 1400 lumen



AceSaver



Replace your old light bulbs with the latest in LED technology that helps you save 90% of your energy compared to incandescent bulbs. Acesaver is available in different wattages with considerable lumen levels. Acesaver is a retrofit option, making it easy for you to replace out-dated lamps. Change to an energy efficient future with Acesaver.

Product features:

- Upto 40% energy saving over 15W CFL*
- Long life upto 15 years*
- Light output of 806 lumen



Architectural **lighting**

Page No. Product

200	Transforming lighting with Philips Color Kinetics
204	Color-Changing LED Lighting Systems
206	EssentialWhite LED Lighting Systems
208	EssentialColor LED Lighting Systems
210	IntelliHue LED Lighting Systems



Philips Color Kinetics

Philips Color Kinetics offers LED lighting solutions in architectural, theatrical, accent, and general indoor and outdoor illumination. Our wide portfolio includes professional LED wall grazing, wall washing, floodlighting, spotlighting, cove lighting, stage lighting, direct view, and general lighting fixtures.

We have extensive experience in successfully illuminating signature façades, landmarks, and interiors around the globe since 1997. Color Kinetics is known for the longevity and reliability of its' LED lighting solutions.

Our IntelliHue, IntelliColor, IntelliWhite, Essential Color, and Essential White LED lighting fixtures are ideal for applications as

diverse as simple under-cabinet lighting, subtle accent lighting, dynamic effect and stage lighting, exterior architectural floodlighting, and stunning displays incorporating tens of thousands of individually controllable points of light.

We offer a full range of DMX and Ethernet lighting controllers specifically designed to work with our LED lighting fixtures, from simple wall mounted controllers to professional software / hardware control solutions. Our LED lighting controllers integrate seamlessly with leading third-party control solutions, lighting consoles, advanced show control systems, occupancy sensors, and building automation systems.

Transforming lighting
with our **expertise and
commitment to innovation**

Expertise

Philips Color Kinetics offers an unmatched depth of expertise, stellar track record, and unparalleled industry knowledge.

Versatility

Philips Color Kinetics offers meaningful LED lighting solutions in architectural, theatrical, accent, and general lighting applications, both indoors and outdoors.

Ease of use

Philips Color Kinetics offer superior ease of use in installation, configuration, programming, and maintenance.



Color changing LED lighting systems

Intelligent color-changing LED lighting systems from Philips Color Kinetics offer intensely saturated, controllable light for interior and exterior architectural applications, intricate light shows, large-scale video and dynamic accent lighting. Industry-leading RGBAW theatrical lights offer a significantly expanded color palette and enhanced color precision for professional stage and entertainment environments.

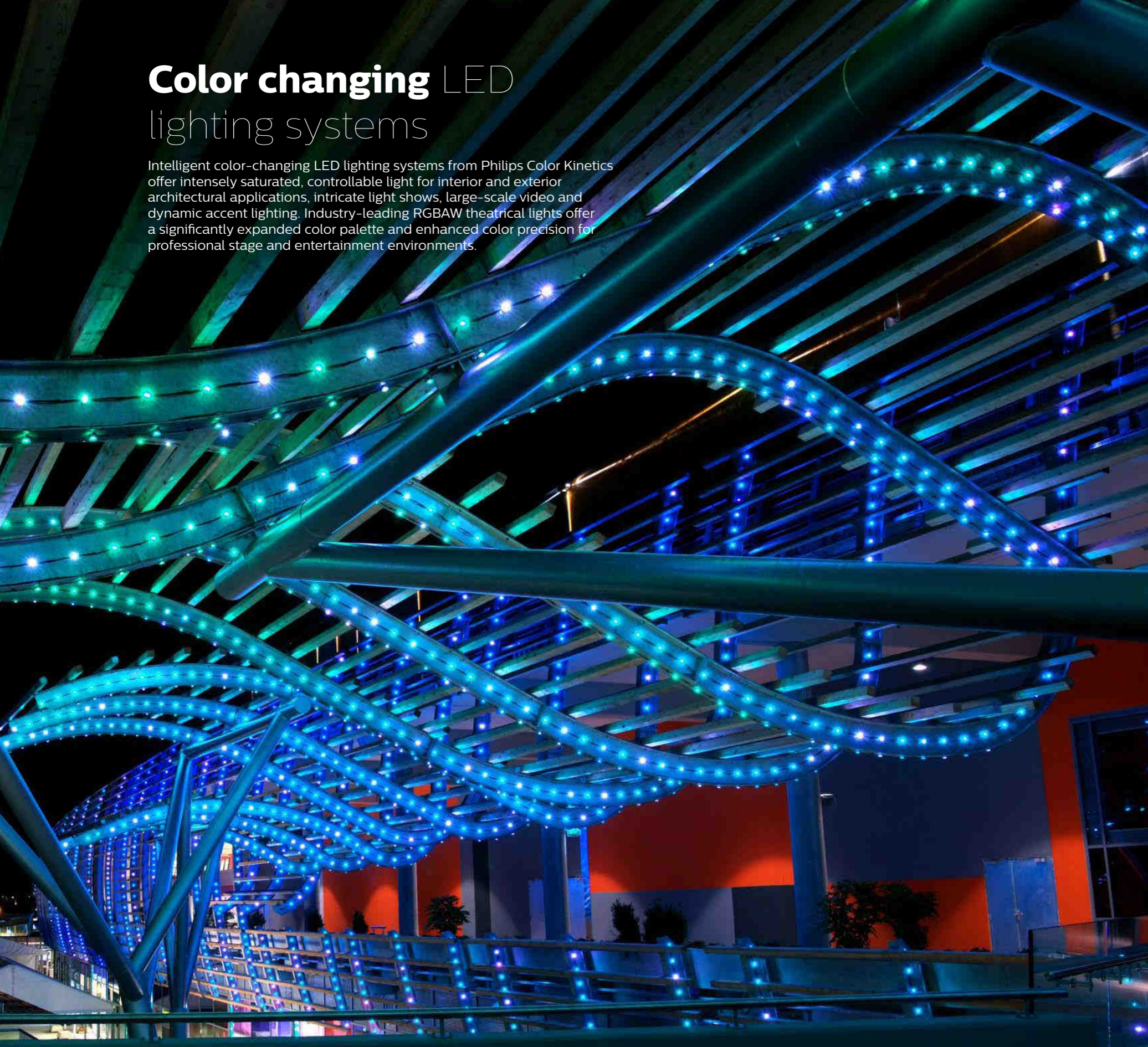

Graze / Wash LED Lighting Systems



Flood / Spot LED Lighting Systems



Cove LED Lighting Systems



Direct View LED Lighting Systems

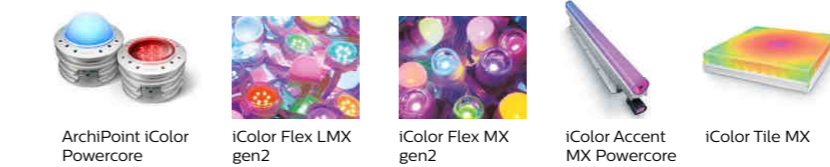

Theatrical / Touring LED Lighting Systems



EssentialWhite LED lighting systems

The EssentialWhite (eW) series from Philips Color Kinetics offers a full-range of professional single-channel LED lighting fixtures, available in a range of color temperatures. Fixtures in the eW series offer all of the advantages of LED lighting including long useful source life, energy efficiency, simplicity of installation and no maintenance operation.



Graze / Wash LED Lighting Systems



Flood / Spot LED Lighting Systems



Cove LED Lighting Systems



Direct View LED Lighting Systems



Task Downlight LED Lighting Systems



EssentialColor LED lighting systems

The EssentialColor (eColor) series from Philips Color Kinetics offers a full range of professional single channel LED lighting fixtures, available in a range of solid colors. Fixtures in the eColor series offer all of the advantages of LED lighting including long useful source life, energy efficiency, simplicity of installation and no maintenance operation. eColor fixtures from Philips Color Kinetics can be connected directly to line voltage and can be dimmed with selected commercially available reverse-phase (ELV-type) dimmers.



Graze / Wash LED Lighting Systems



Flood / Spot LED Lighting Systems



Cove LED Lighting Systems



IntelliHue LED Lighting Systems

IntelliHue, an advanced approach to color mixing, enables high-quality intelligent color and white light from the same fixture. Multiple channels of LED light sources are combined to produce a full spectrum of precisely controllable light, including millions of saturated colors, pastels, and uniform white light with high color accuracy across the entire range of color temperatures.

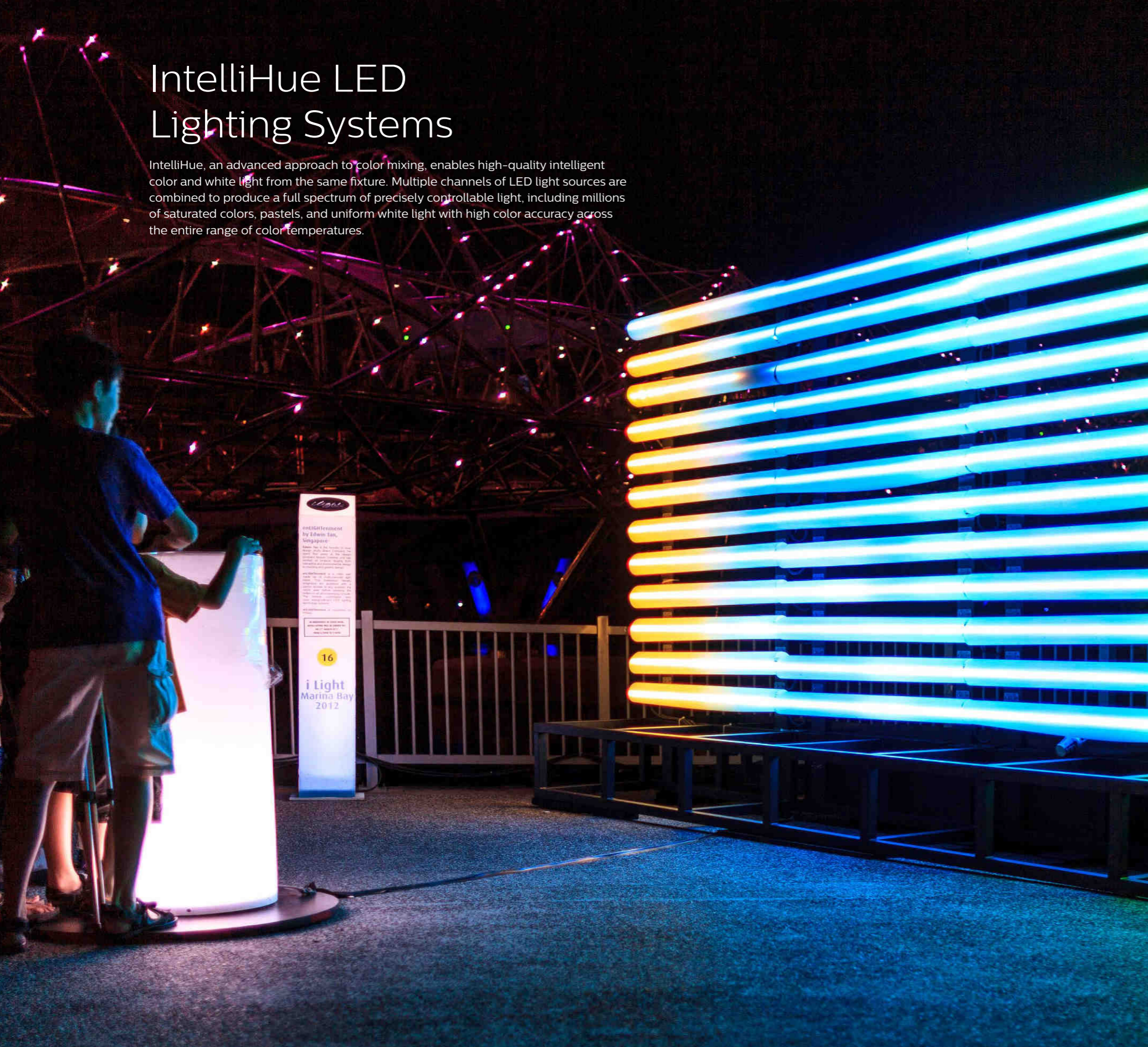

Graze / Wash LED Lighting System



SkyRibbon IntelliHue
Wall Grazing Powercore



SkyRibbon IntelliHue Wall
Washing Powercore

Direct View LED Lighting Systems



SkyRibbon IntelliHue Linear
Direct Powercore

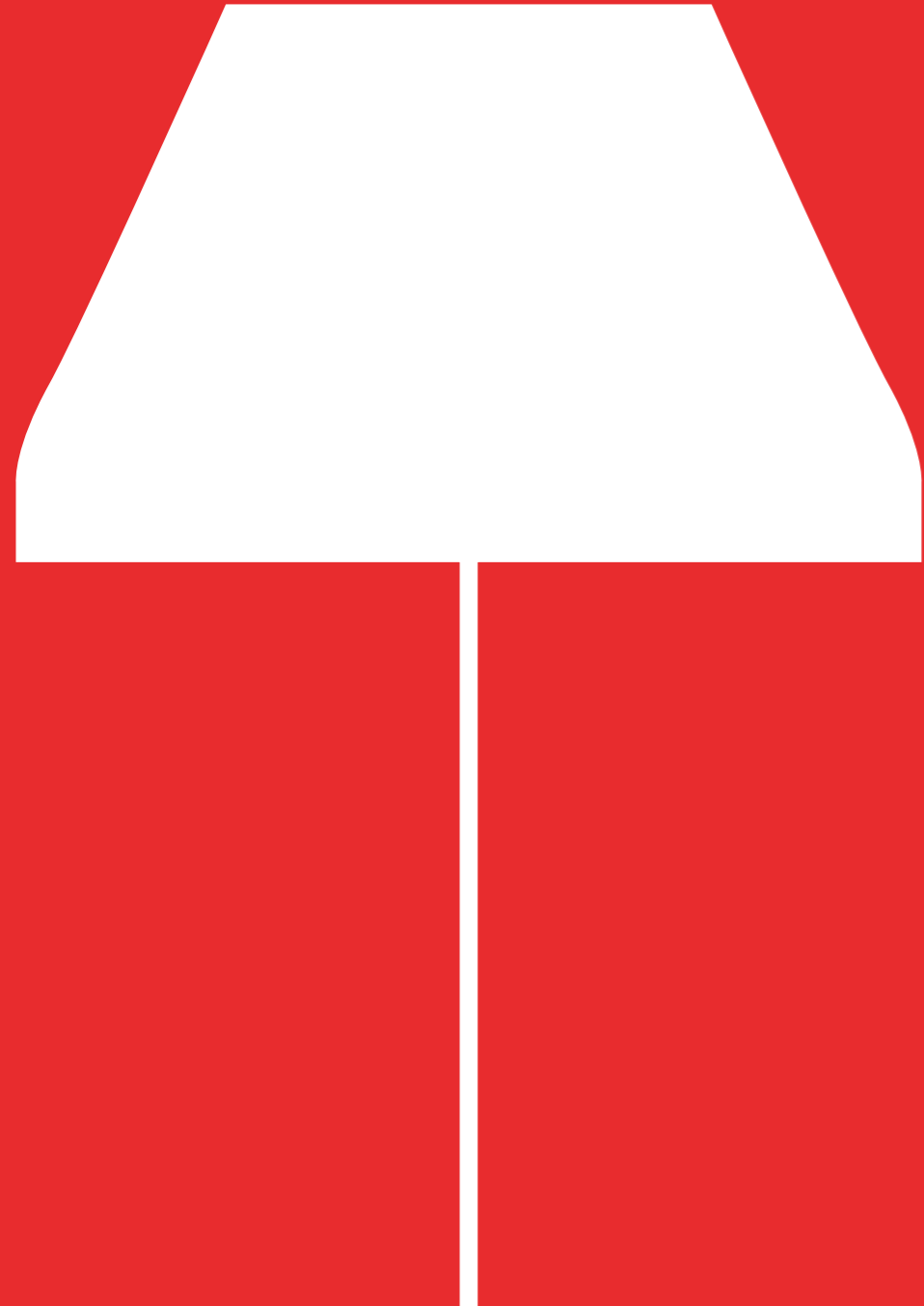

Home
lighting



Lights for a **relaxing home**

Home is where the heart is. A place where you can be yourself.
This collection of contemporary lights reflects your style and while
maintaining your need for comfort.

Light so **pure** **and modern**

Simplicity and purity are the design themes in the modern living home, the perfect backdrop for these beautifully crafted lights. Sometimes, the simplest things are the most beautiful.

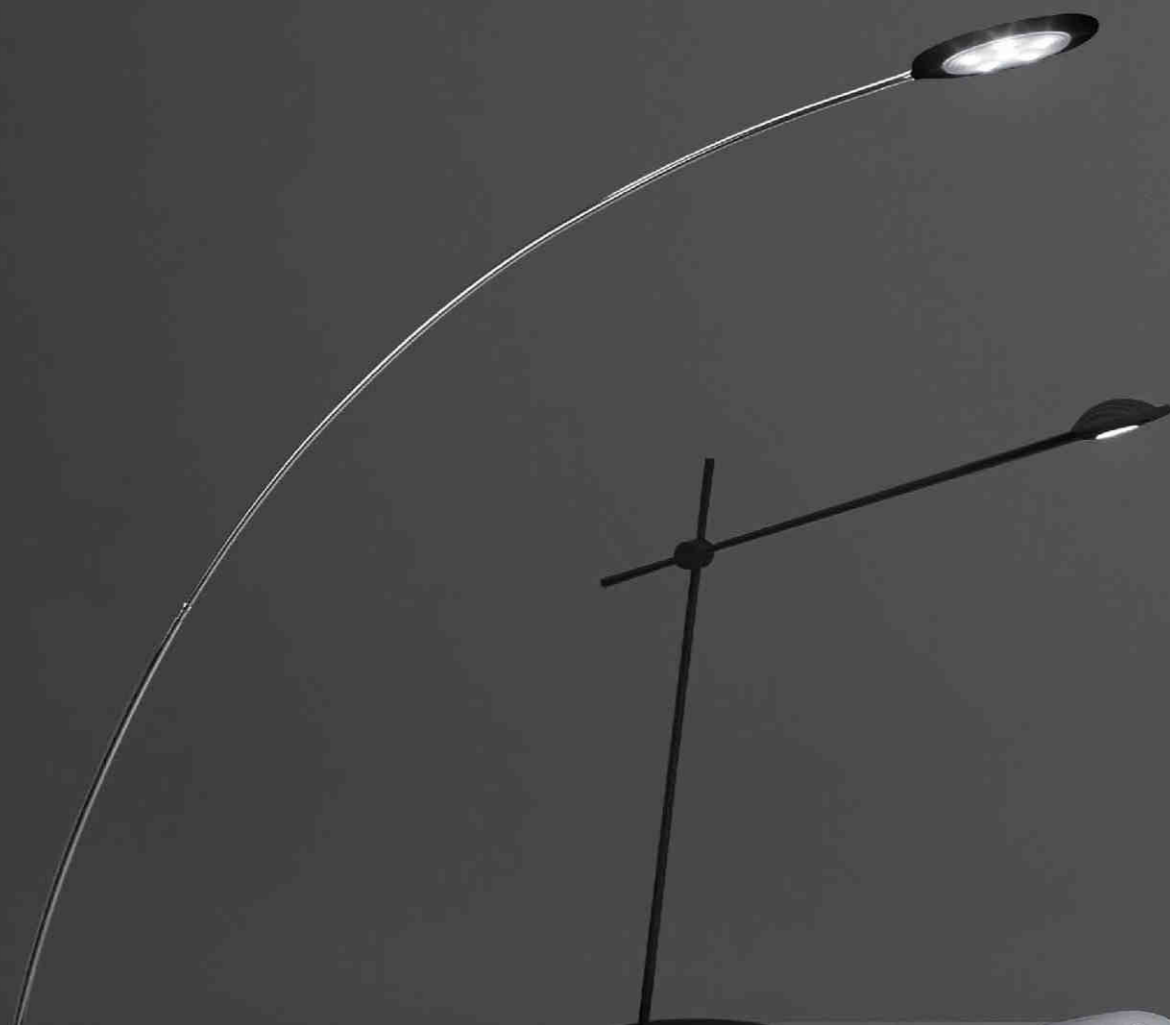
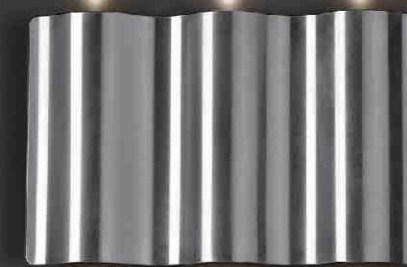
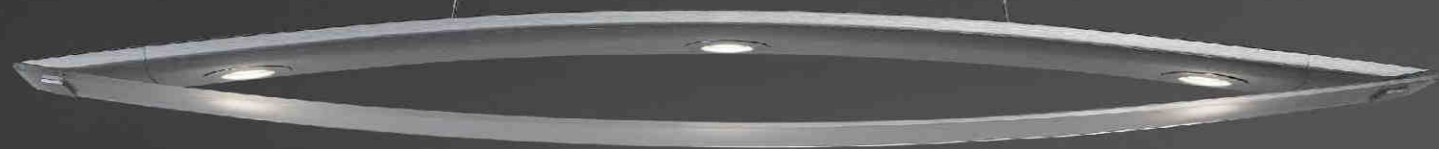



Light to **imagine** **and inspire**

Light that surprises and delights. A bagful of character, a sprinkle of wit, and a big dose of creativity are the ingredients that go into making this unique portfolio of lights.





Memories **with** **a new glow**

Design to complement homes that are inviting and warm, these lights combine traditional accents with a fresh design aesthetic.



Bring **sparkle** **and elegance**

An exquisitely crafted portfolio of lighting masterpieces, inspired by centuries of luxurious styling combined with technology. Essential for today and easy to use.



Lighting **controls**





Transforming environments

with lighting control
solutions

Create sophisticated, reliable and energy efficient lighting controls for residences, offices, retail, hospitality, industry, public spaces and more.

Philips dynalite invests significantly in R&D to remain world leaders in lighting

management systems. We are globally recognized for delivering distinctive and long-lasting solutions. Moreover, we are also the system of choice for projects requiring integration with third parties.

Lighting controls for dynamic environments

Philips Dynalite specialises in the provision of end-to-end intelligent lighting control systems, rather than just products. We know that the critical link between products like lamps, luminaires and LEDs and a fully integrated solutions environment, is the control capability. Lighting control infrastructure underpins the fully integrated environment that is

the future of building and energy management systems worldwide.

By combining our control systems with our broad selection of energy efficient luminaires, users can create custom ambiances or even transform their current environment by the flick of a switch.

Office



Ensure optimum lighting levels in public spaces. In addition to this, smart light controls allow you to create dynamic light effects effortlessly.

Retail



Enriches shopping experiences while also providing superior energy management capability.

Hospitality



Controls that help create inviting spaces through dynamic light effect. Use of these unique themes and lightscapes also create brand differentiation for hospitality organizations.

Public spaces



Lighting controls help in ensuring adequate lighting levels across public spaces. It helps in creating dynamic light effects through controllability.

Smart homes



Express individual personality and style and create atmospheres tailored to function, mood or occasion with intelligent lighting control solutions that are easy to use.

User interface

Philips Dynalite user interfaces come in a wide range of styles and finishes to match any project budget or décor requirements. This range includes wall panels, touchscreens, universal sensors, timer clocks and temperature sensors.



Antumbra series

Revolution series

Classic series

Standard series

Sensors

Bring the features of motion detection, light level detection and IR receive into one unit, operating at the same time. Automation scenarios like turning on lights after detecting motion and dimming light levels once sun light has been measured, provides additional energy savings. Unoccupied areas for a predetermined amount of time, will automatically turn lights off. Reduce the clutter of many different sensors in a ceiling space.



Multifunction sensors

Temperature sensors

Relay and multipurpose controllers

As two of the most popular forms of lighting control, relay and multi-use devices can have high impact on energy management. Available in both DIN rail and wall box configuration, Philips Dynalite supports a vast range of relay controllers with a variety of circuit numbers and sizes to work individually or as part of a system, suiting any project requirement.



Relay and multipurpose controllers

Dimmers and controllers

Philips Dynalite supports a wide selection of dimmer units that are compatible with most lamp types. An unlimited number of combinations of dimmer units can be chosen to work together in one project allowing for a spectacular end result. Ultra-smooth dimming in projects where it's critical for flicker-free scene changes.



Leading edge dimmer

Trailing edge dimmer

Signal edge dimmer

Guest room controllers

Device and software integration

Philips Dynalite range of gateway devices can be used to synchronize their functions together into one integrated system solution. By successfully integrating third-party systems with Philips Dynalite, repetitive interaction from end-users is reduced. A range of different gateways have been developed to provide different integration opportunities and network management options.



Envision Gateway
Envision Software
Envision project
Envision manager
DDNG-BACnet gateway

Philips Lighting Academy

Taking the lead in lighting



Philips Lighting Academy is a special initiative of Philips India Limited. It was set up in late-2011 to foster multi-level learning on lighting theory, design, innovation and application in the Company's internal and external stakeholders.

The Academy was born out of a global decision to prioritize knowledge as the foremost requirement for meeting the demands and challenges of a fast-changing lighting world. With digitization transforming lighting technologies and forcing paradigm changes in the ways lighting had been perceived and transacted for years the world over, it had become imperative to mandate everyone connected with lighting to refresh traditional lighting knowledge and acquire new knowledge on digital technologies.

"Sharpen the axe" had emerged as the new survival strategy.

Philips Lighting Academy brings simple, user-friendly e-learning, completely free, on its website on handpicked lighting subjects:

- Introduction to Lighting Theory and Application
- Understanding LED Technology
- Lamps – Incandescent, Halogen and Fluorescent
- Introduction to Luminaires

"Winning Together" – a Philips Lighting Academy exclusive

"Winning together" is a learning program specially conceived and designed primarily for architects, designers and electrical consultants. It brings easy online learning on a wide and comprehensive array of lighting subjects, ranging from LED technology, lamps and luminaires to creative lighting, architectural lighting and sustainability.

Through these, the program helps ensure:

- Access to Philips's knowledge experts for customized knowledge solutions on Philips products and services
- World-class learning solutions with world-class learning tools
- Specially designed courses and curriculums for architects, interior designers, electrical consultants, students, self-employed professionals, government and corporates
- Certifications to strengthen professional credentials and help market-positioning with clear competitive edges
- Self-directed web based learning at the learner's pace, time and convenience.

"Winning Together" also brings an exclusive series of webinars by Indian and Global experts, designed and developed for a select audience on such topics as:

- Green Lighting Solutions
- Choosing your LED Products
- Standards and Lighting Design
- Intelligent Lighting System
- Light & Sustainability

The Academy's training tools:

- Publications
- Online standalone learning modules
- Special online certifications by Philips Lighting Academy for standalone and short-term programs
- Webinars / webcasts / e-classrooms
- Exclusive live classroom sessions

A huge library of recorded lectures and webinars

Learning from Philips Lighting Academy is easy, affordable and fun. To know us better, visit us at www.lighting.philips.co.in/connect/Lighting_Academy or write to us at LiteAcademy.India@philips.com

Converting **vision** into **reality**

The ideal solution for any lighting application is based on many factors such as the area being illuminated, the lighting technology being used, the aesthetics of the setting, environmental constraints, etc. Even with an extensive product range, it is not always possible to satisfy each and every requirement of a project. Therefore, at Philips we have a team

of lighting application and product development specialists who work with you to provide lighting solutions that are perfect for you. The examples showcased here demonstrate how creative vision and technical expertise can together bring imagination to life. Something that quite simply, creates delight with lighting.

**Audi Offices
Neckersulm, Germany**
Page 236



Lighting solutions that enhance employee comfort and efficiency

**Gateway of India
Mumbai, India.**
Page 238

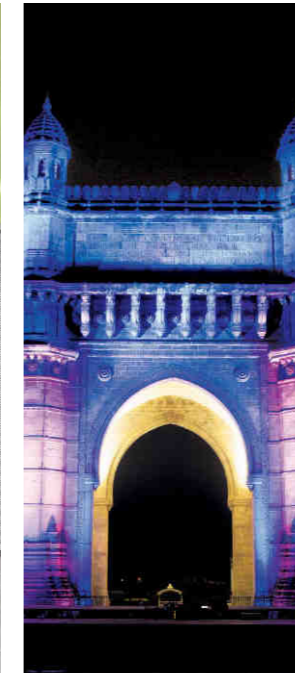

Light up your love affair with your city all over again

**Dragon bridge,
Da Nang, Vietnam**
Page 240



Bringing prosperity to lives of people

**Phoenix,
Arizona, USA**
Page 242



Create an enchanting and comforting environment

**EDUCITY Sports Complex,
Johor Bahru, Malaysia**
Page 244

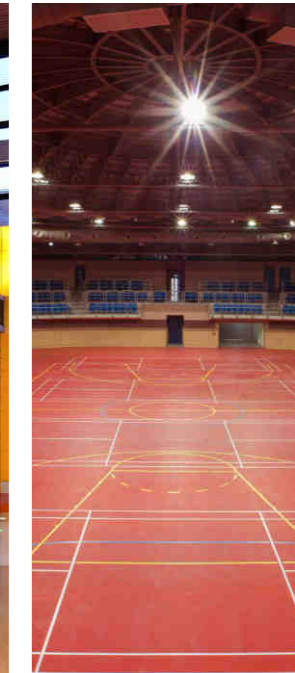

Quality light for the wellbeing of players, officials and spectators

**Natural History Museum
London, UK**
Page 246



Giving pleasure and enjoyment to millions of visitors each year



Innovative lighting to **enhance comfort and efficiency** of employees

**Audi Offices
Neckarsulm, Germany**

◀ Audi opted for Philips LED technology which centred around the new PowerBalance recessed luminaire and LuxSpace Mini LED downlights, using Fortimo technology.

With Power balance, exceptional light quality and high energy efficiency is achieved through the high-quality LEDs paired with 16 highly reflective Smart Pyramid optical elements, which distribute the light evenly around the space. The color reproduction and glare reduction of the screen compatible luminaires satisfy the requirements of Workplace Standard EN12464-1. On the other hand, LuxSpace Mini LED downlights provided attractive appearance combined with durability and high system efficiency.

“ The decision to fit out the entire third floor of our office with LED lighting was one of the best of the year. We’re also making clear energy savings through the innovative lighting management. In addition, our colleagues feel great in the new atmosphere and are more motivated than ever.”

Property Management, AUDI AG Neckarsulm



LuxSpace



Powerbalance

Light up your love affair with your city all over again

Gateway of India
Mumbai, India

Philips in partnership with Maharashtra Tourism Development Corporation (MTDC) gave a lighting makeover to Mumbai's iconic archway Gateway of India. With Philips Color Kinetics lighting system, the lighting scenes on the façade and mast of the iconic Gateway of India now change in real-time. This technologically-advanced LED lighting system, offers a palette of 16 million shades that can be programmed to create dynamic and unique lighting shows. With the new LED fixtures, the beautiful monument can be easily automated in real-time by a computer control system to create unique light shows with varied effects like ripple, cross-fade, particle and burst. The system will also simplify the maintenance schedule, as well as monitor unforeseen issues such as power outages. This new lighting of the Gateway of India not only makes it a visual treat for citizens and tourists alike, but also drives the message of choosing environment friendly LED lighting solutions so as to get the best of lighting and consume the least of energy!



ColorReach Powercore



ColorBlast Powercore

“It is a delight to see a company like Philips taking the initiative of transforming the night time view of the Gateway of India with lights. With a successful record of lighting up historical monuments in India, we are sure that Philips will yet again bring alive and transform Mumbai's most admired monument through various possibilities of lighting.”

Dr Jagdish Patil, Managing Director,
Maharashtra Tourism Development Corporation





Bringing prosperity to lives of people

Dragon bridge, Da Nang, Vietnam

◀ As a strong advocate for the use of sustainable energy, the city government of Da Nang was looking for a lighting solution that is energy efficient and would help turn the unique steel bridge into a new icon of Da Nang city.

The Philips LED lighting solution brought to life the design of the dragon that seems to leap out of the Han River through a stunning display of colors, with lighting that is both environmentally sustainable and energy efficient and can be customized for any occasion, festival or holiday making it as a gateway for Vietnam and the rest of the world to the city of Da Nang.

“ This unique and beautifully lit bridge is set to become Da Nang’s new landmark, an ever changing functional artwork that puts Vietnam on the world map of lighting design.”

Dr. Tran Van Thanh, Lighting Designer, ASA Studios



iColor Tile MX



ColorBurst Powercore



Vaya Linear

Creating a magical and comforting environment

Phoenix, Arizona, USA

With the help of Philips color kinetics HKS created an immersive escape for patients and families, a distraction from the medical ailments surrounding them in the hospital interiors. Upon entering the building, patients and visitors find themselves in a cheerful, colorful lobby up-lit with rows of concealed, color-changing iColor Cove MX Powercore fixtures. While the exterior design, got a distinctive look that could be easily seen from almost any direction.



iColor Tile MX



iColor Cove MX Powercore



iColor Accent Powercore

“Only Philips Color Kinetics had the quality, specialized product offerings, and customer service needed to realize our vision.”

Scott Oldner, Scott Oldner Lighting Design





Quality light designed for the **wellbeing of players**

**EDUCITY Sports Complex,
Johor Bahru, Malaysia**

◀ *Iskandar Group is developing an Education City (EDUCITY) in Johor Bahru, which houses a number of international universities. They wanted to provide a world-class infrastructure that would be able to host sporting events and looked for a suitable lighting solution. The sports complex was built with various sports facilities which includes a soccer stadium, swimming stadium and indoor sports arena that will host badminton, basketball and futsal games.*

Each individual sport has precise lighting requirements to be met (lighting levels, uniformities, etc.). Aside from specific sport requirements, the lighting also had to offer excellent color rendition and glare control with minimum spill light to avoid light pollution.

The lighting solutions offered an excellent lighting quality which improved the performance of the players and offered exceptional viewing experience. Adequate lighting levels, good uniformity and freedom from glare were achieved as it was designed with the well-being of players, officials and spectators in mind.

“ *The new lighting solutions have fulfilled our expectations on providing a world-class sports complex with a favorable sporting environment, be it day or night, for both competitive and recreational sporting events.*”

*Muhammad Suhaili Azid, Assistant Vice President,
EDUCITY Development*



ArenaVision



Landmark



OptiVision

Creating a spectacle for millions of visitors each year

London, UK

Visitors to the Natural History Museum cannot fail to be impressed by the grand entrance and rounded arch of one of Britain's most striking examples of Romanesque architecture. The magnificence of the structure at night, however, was not being optimized by the existing lighting solution, which used inefficient metal halide floodlights. Philips ColorReach™ Powercore has given the Natural History Museum even greater scope to integrate stunning lighting effects within its architectural environment and, in so doing, brings even greater pleasure and enjoyment to its millions of visitors each year. Switching to an LED alternative offered multiple benefits including benefiting from significantly lower annual running costs, as well as the opportunity to truly bring out the aesthetic quality of the building.



iColor Tile MX



Signature Lighting Collection for creative visionaires

The world of lighting is moving into a new era. We are facing enormous challenges and exciting opportunities. In such times, co-creation is the key to creating compelling lighting experiences.







With our experience and your vision, we can turn imagined concepts into tangible new solutions.







Signature Lighting Collection is a showcase of products that allow you to meet your lighting needs and empower you to see your vision as reality.

Products Overview

Indoor lighting





Page 48 - 133





Arcus		50
BoldPlay		56
Chopstick		62
CoreView		68
CoreLine Proset		74
DayWave		80
DayZone		86

eW downlight		92
Jump		98
Lumistone		104
LuxSpace		110
Rotaris		116
StyliD		122
TurGroove		128

Outdoor lighting

Page 134 - 183

Amphilux		136
Arena Vision		142
City Spirit		148
Decoflood		154

Decoscene		160
Mini Stealth		166
Luma		172
Jargeau		178

LED lamps

Page 184 - 197

MR16	188	Master LED PAR	193
GU10	189	Nova Glow	194
Master LEDtube	190	MR11	195
Essential LEDtube	191	Stellarbright	196
AR111	192	AceSaver	197

Architectural lighting

Page 198 - 211

Color-Changing LED Lighting Systems	204	EssentialColor LED Lighting Systems	208
EssentialWhite LED Lighting Systems	206	IntelliHue LED Lighting Systems	210

Home lighting

Page 212 - 223

Lighting controls

Page 224 - 231

“In the right light, at the right time, **everything is extraordinary.**”

Aaron Rose, Photographer

South

Philips India Ltd,
Temple Towers, 5th. Floor,
Old no. 476, new no. 672,
Anna Salai, Nandanam,
Chennai 600 035
Tel :- 91 44 6650 1000
Fax :- 91 44 6650 1075
lighting.india@philips.com

Philips India Ltd,
Philips Innovation Campus
Manyata Tech Park, Nagavara
Bengaluru-560045
Tel : 080-4189 0000
Fax :- 080 6692 9930
lighting.india@philips.com

Philips India Ltd,
6-3-1109 / I / P/ 103, 3rd floor
Jewalpwani Towers, Rajbhavan
Road, Somajiguda, Hyderabad
Tel :- 040 6646 7676 / 4825
Fax :- 040 6678 7974
lighting.india@philips.com

West

Philips India Ltd,
Technopolis Knowledge Park,
Mahakali caves road,
Chakala, Andheri East,
Mumbai 400093
Tel :- 91 22 6691 2000
Fax :- 91 22 6691 2389 / 6691 2398
lighting.india@philips.com

Philips India Ltd,
602, Heritage Tower, 6th floor,
Behind Visnagar Co-op Bank,
Near Gujarat Vidyapith, Usmanpura,
Ahmedabad, Gujarat
Tel :- 91 79 2754 0708
Fax :- 91 79 2754 0666
lighting.india@philips.com

East

Philips India Ltd,
7, Justice Chandra
Madhab Road,
Kolkata 700 020
Tel : 91 33 2486 7621-24
Fax : 91 33 2486 8318
lighting.india@philips.com

North

Philips India Ltd,
9th Floor, DLF - 9B, DLF
Cyber City DLF Phase 3,
Gurgaon 122002
Tel :- 91 124 460 6000
Fax :- 91 124 460 6666
lighting.india@philips.com

Philips India Ltd,
8th floor, DLF - 9B, DLF Cyber City
DLF phase 3, Gurgaon 122002
Tel :- 91 124 460 6000
Fax :- 91 124 460 6666
lighting.india@philips.com

For more information contact us at lighting.india@philips.com or call at 1800 102 2929
SMS 'LED' to 58888

www.lighting.philips.co.in

